

4.6.2. Vertical Front Connection

▪ Bottom Outlet Connection: Straight Terminal

1. Connect the earthing switch.
2. Remove the cover to access the cable compartment and install the fixing pins used to secure the terminals. Turn them so that the terminals can be installed.
3. Connect the terminals on the bushings and adjust the pins with the tensioner. Then secure the cables with the cable bracket and the clamp.
4. Connect the terminals' earth connectors, if applicable, and the cable screens' earth connectors.
5. Put the cable compartment cover back into place.

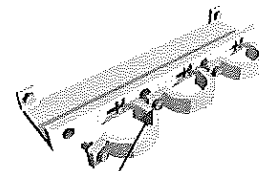
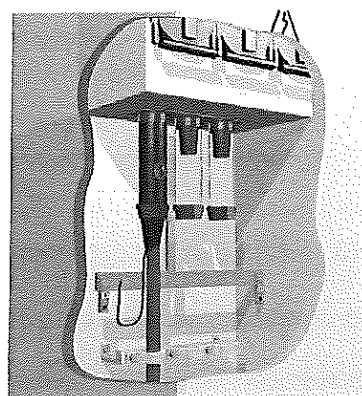
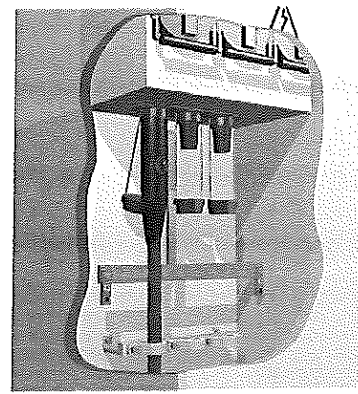

Note: The clamp has two positions, depending on the cable diameter.

Figure 4.35: Front connection in cubicle protection functional units

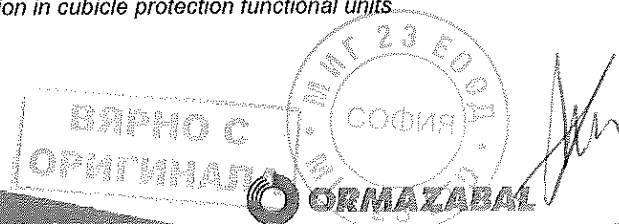

▪ Rear Connection in Modular Cubicles

Rear connection in 1300 mm High Modular Cubicles

1. Connect the earthing switch.
2. Remove the front cover to access the cable compartment.
3. Unscrew the four screws of the cable bracket (A) and the rear rack (B). Keep them for subsequent steps.
4. Remove the rear rack and the cable bracket.
5. Anchor the bracket to the rear, using the screws provided (C).
6. Position the terminals' fixing pins (D). Turn the pins so that the terminals can be installed.
7. Connect the terminals on the bushings (E).

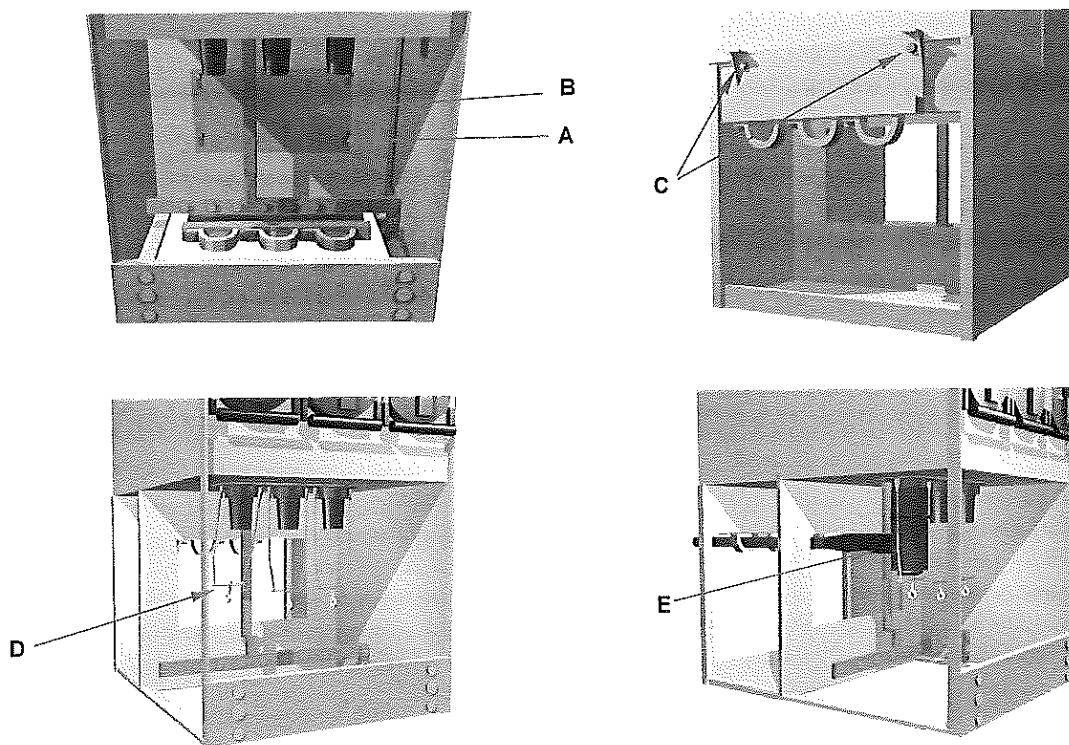

Figure 4.36: Rear connection in 1300 mm high modular cubicles

8. Adjust the pins to the terminals using the tensioner. Likewise, secure the cables with the cable bracket (F).
9. Connect the terminals' earth connectors, if applicable, and the cable screens' earth connectors.
10. Install the rear rack removed in step 4, at the front (G), putting it in back to front. The slide slots must fit in the rails of the rack (H). Tighten the screws loosened in step 3.
11. Put the cable compartment cover back into place.

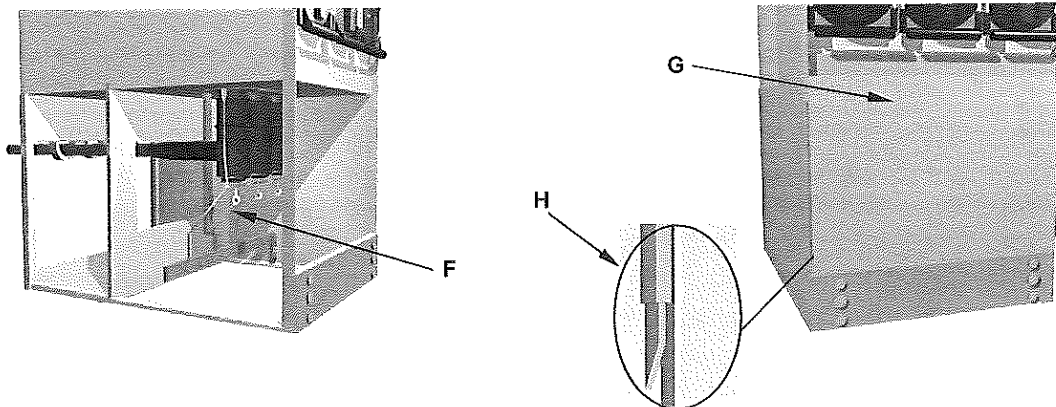

Figure 4.37: Rear connection in 1300 mm high modular cubicles

Rear connection in 1740 mm High Modular Cubicles

1. Connect the earthing switch.
2. Remove the front cover to access the cable compartment.
3. Loosen the rear support rack's (A) screws.
4. Slide the rack to open the holes or dismantle it for easier assembly.

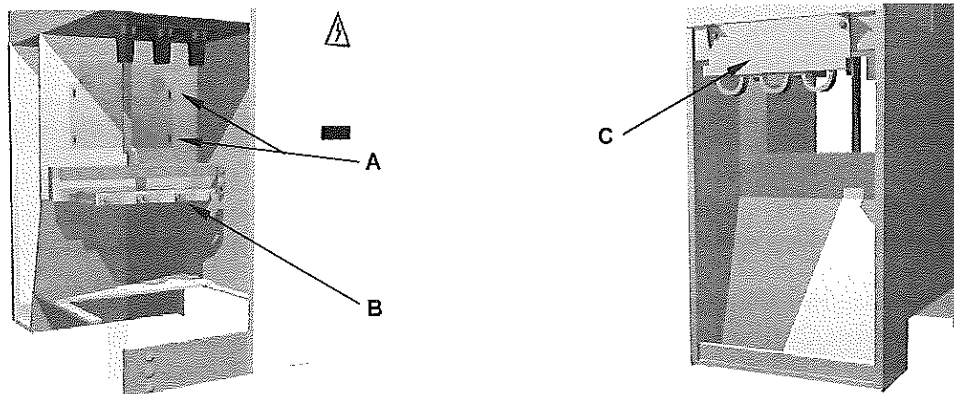

Figure 4.38: Rear connection in 1740 mm high modular cubicles

5. Remove the cable bracket (B) and place it at the rear of the cubicle (C).
6. Position the terminals' fixing pins (D). Turn the pins so that the terminals can be installed.
7. Connect the terminals on the bushings (E).
8. Cinch the pins to the terminals using the tensioner (F).
9. Adjust the two parts of the support rack to the cable size and tighten the screws.
10. Connect the terminals' earth connectors, if applicable, and the cable screens' earth connectors.
11. Put the cable compartment cover back into place.

ВЯРНО С
ОРИГИНАЛ



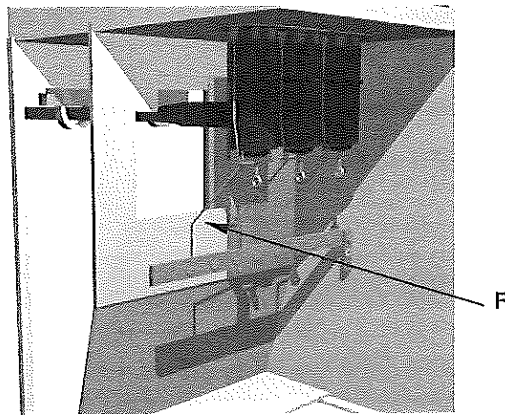
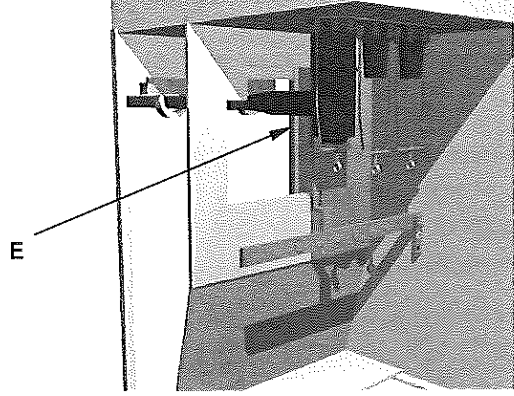
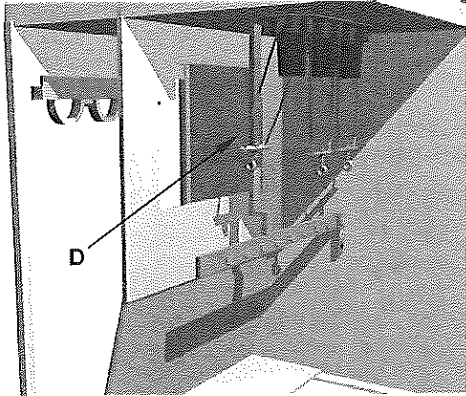

Figure 4.39: Rear connection in 1740 mm high modular cubicles

▪ **Rear Connection in Compact Cubicles**

Rear Connection in 1300 High Compact Cubicles

1. Connect the earthing switch.
2. Remove the front cover to access the cable compartment.
3. Remove the rear rack (A).
4. Remove the cable bracket (B) and attach it at the rear (C).
5. Place the rear rack in the lower part of the cubicle (D).
6. Position the terminals' fixing pins (E). Turn the pins so that the terminals can be installed.
7. Connect the terminals on the bushings (F).
8. Cinch the pins to the terminals using the tensioner (G).
9. Connect the terminals' earth connectors, if applicable, and the cable screens' earth connectors.
10. Put the cable compartment cover back into place.

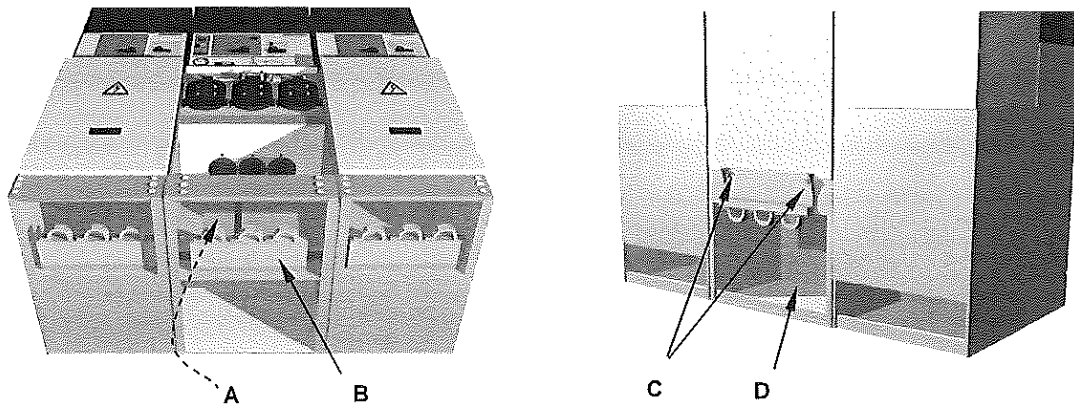

Figure 4.40: Rear connection in 1300 mm high compact cubicles

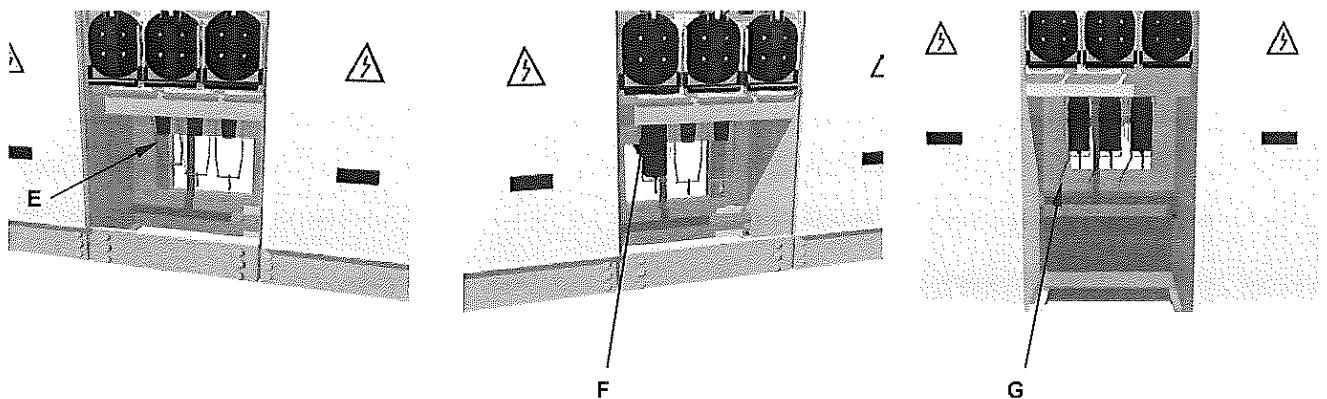

Figure 4.41: Rear connection in 1300 mm high compact cubicles

ВЪРНО С
ОРИГИНАЛ
ОРМАЗАВАЛ

М МТ 23 ЕО Д
СОФИЯ
РИФО

Rear Connection in 1740 mm High Compact Cubicles

1. Connect the earthing switch.
2. Remove the front cover to access the cable compartment.
3. Remove the rear rack (A).
4. Remove the cable bracket (B) and attach it at the rear (C).
5. Place the rear rack in the rear part of the cubicle (D).
6. Position the terminals' fixing pins (E). Turn the pins so that the terminals can be installed.
7. Connect the terminals on the bushings (F).
8. Cinch the pins to the terminals using the tensioner (G).
9. Connect the terminals' earth connectors, if applicable, and the cable screens' earth connectors.
10. Put the cable compartment cover back into place.

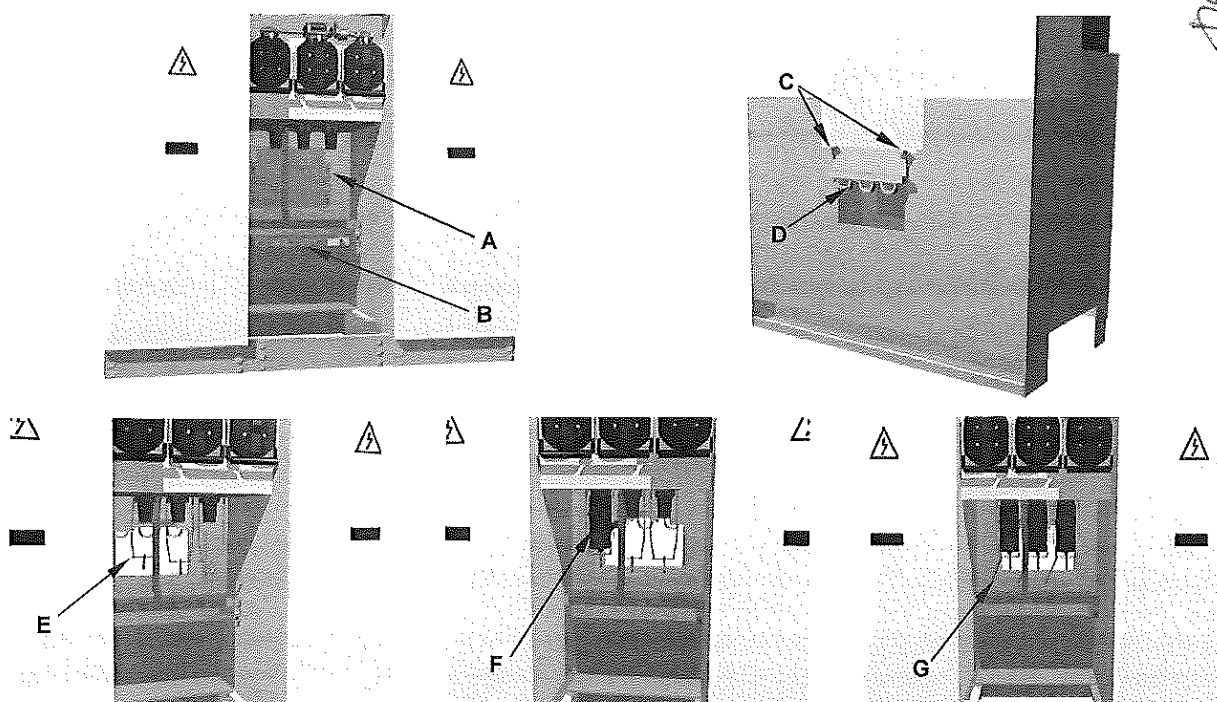

Figure 4.42: Rear connection in 1740 mm high compact cubicles

4.6.3. Types of Bushings

- IEC
- 250 A rated bushings, at 12 and 24 kV, commercial elbow or straight connectors on dry cable. (examples: K158LR, 152SR from Euromold)

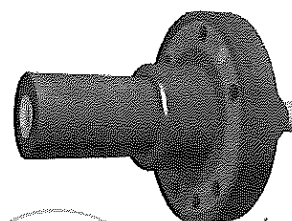

Figure 4.43: 250 A plug bushings

- 400/630 A rated bushings, at 12 and 24 kV, for plugged, shielded and unshielded commercial connectors, on dry cable and oil-impregnated paper insulation cable (examples: K400LR, K400TB from Euromold)

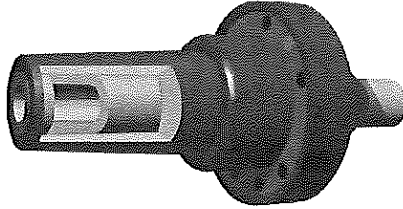

Figure 4.44: 400 A plug bushings

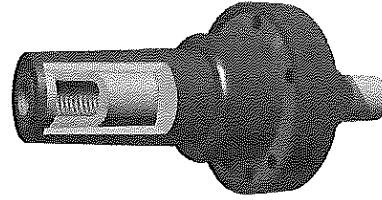

Figure 4.45: 630 A screwable bushings

▪ ANSI compatible (IEEE-386 Compliant)

- 400/630 A rated bushings, at 12 and 24 kV, for commercial elbow or straight connectors on dry cable.

In those cases where connectors are used without earthing between the MV cable and the cubicle, specific adaptors must be requested from Ormazabal^[16].

4.7. METERING TRANSFORMERS

The voltage and current transformers are mounted in the respective position according to the requested diagram, and the types of transformers to be assembled.

The maximum number of transformers that can be installed is 6: three voltage and three current transformers.

The Metering cubicle accepts the following standard transformers:

	ARTECHE	LABORATORIO ELECTROTÉCNICO	ACTARIS
VOLTAGE	UCH-12 UCJ-24 VCL-24 UXN-24 VCJ-24 UXJ-24 UCL-24 VXJ-24	VKPE-12 VKPE-24 VCF-24	U24Bha E24Bha U24Bma E24Bma
CURRENT	ACD-12 ACF-12 ACD-24 ACF-24 ACJ-24	AED-12 AEB-24P AED-24 AER-24	J24BM J24BR J24BQ

⚠ IMPORTANT:

Ormazabal is the manufacturer of this metal enclosure. Ormazabal will not be held responsible for the interconnections or any equipment added by third parties. For any other type of instrument transformers, please contact Ormazabal's Technical – Commercial Department.

^[16] For confirmation, contact Ormazabal's Technical – Commercial department.

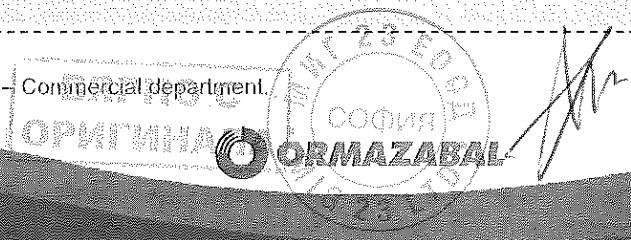

4.8. VERIFICATION OF VOLTAGE PRESENCE AND PHASE CONCORDANCE

To verify correct MV cable connection to the Transformer Substation feeder cubicles, Ormazabal's **ekorSPC**^[17] phase comparator must be used.

First, connect the ekorSPC unit's red cables to the same phase test points of the corresponding ekorVPIS^[18] units, and the black cable to the earth test point. This operation must be repeated for all L1, L2 and L3 phases.

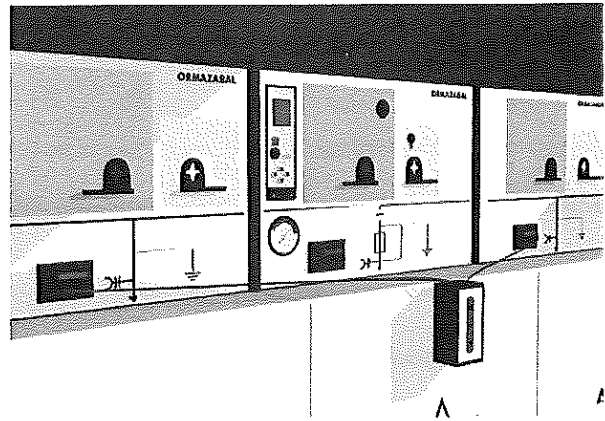
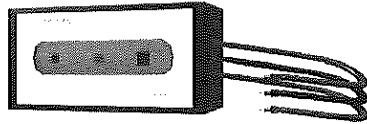
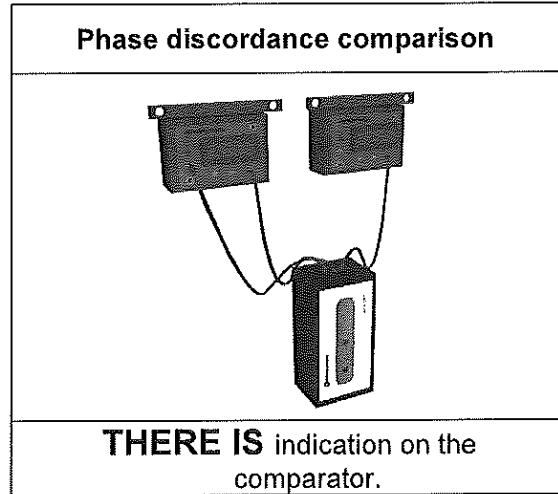
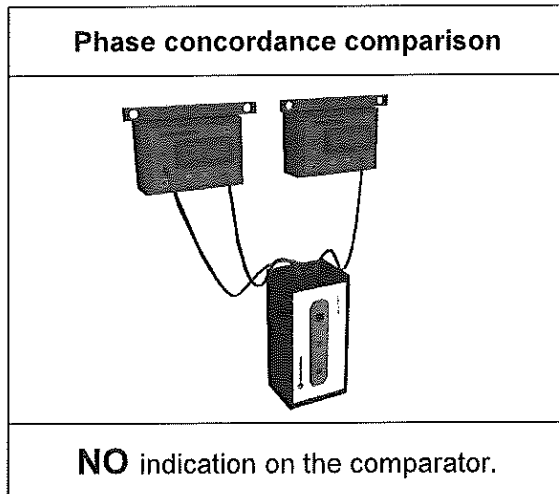

Figure 4.46: ekorSPC



^[17] Optionally, other comparison devices complying with IEC 61958 may be used.

^[18] Refer to section 1.1.1. ekorVPIS – Voltage Presence Indicator Unit.

5. SEQUENCE OF OPERATIONS

⚠ ATTENTION!

Before performing any operation under voltage, check the SF₆ gas using the pressure gauge.

5.1. FEEDER CUBICLE

5.1.1. Disconnection Operation from the Earthing Position

1. Take the yellow slide to its right position (in this way the access for disconnecting the earthing switch is freed).
2. Insert the lever in the earthing switch lever access and turn 90° ANTICLOCKWISE.

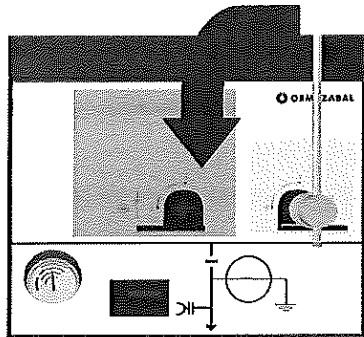

Figure 5.1: Lever Rotation Process

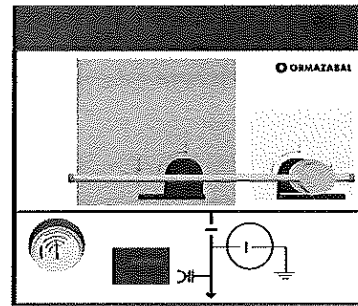

Figure 5.2: Disconnected Earthing Switch

RECOMMENDATION: Although the figure shows the initial moment of the operation with the lever arm vertical, it is advisable to start with the lever arm horizontal and towards the right, in order to make the best use of the force applied by the operator.

5.1.2. Switch Connection Operation from the Disconnected Position

3. Take the black slide from the grey area to its left position (in this way the lever access for connecting the switch is freed).

4. Connection Operation:

4.1. Manual Operation (B Driving Mechanism)

Insert the lever in the switch access (grey area) turn it 90° CLOCKWISE.

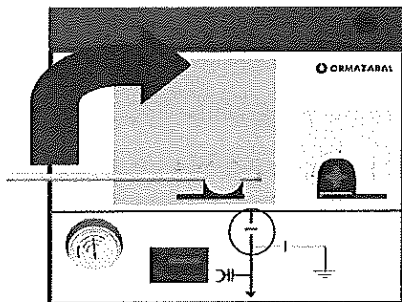

Figure 5.3: Lever Rotation Process

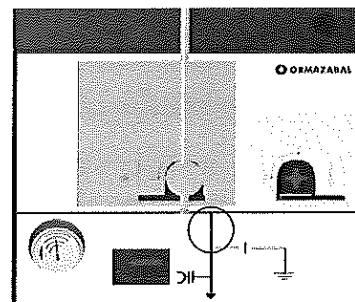

Figure 5.4: Connected Switch-Disconnecter

ВІРНО С
ОРИГІНІ
ORMAZABAL

4.2. Motorised Operation (BM Driving Mechanism)

Activate the corresponding operation command.

⚠ IMPORTANT:

If for any reason half way through a motorised operation the motor stops, it is essential that the operation be finished manually before starting it up again so that all the mechanism, sensors, controllers, etc. are in a reliable, effective and logical position for the motorisation control system when it is connected again.

5.1.3. Disconnection Operation from Connected Position

5. Take the black slide from the grey area to its left position, in the same way as in the previous situation (in this way the access for connecting the switch is freed).

6. Disconnection Operation

6.1. Manual Operation (B Driving Mechanism)

Insert the lever in the switch access (grey area) turn it 90° ANTICLOCKWISE.

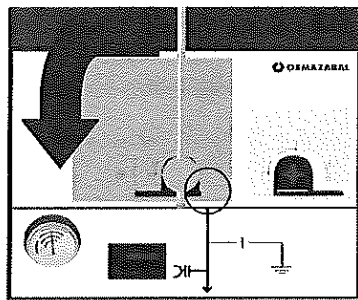

Figure 5.5: Lever Rotation Process

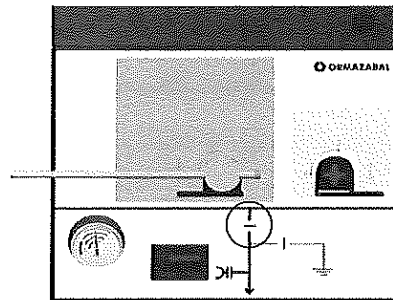

Figure 5.6: Disconnected Switch-Disconnecter

6.2. Motorised Operation (BM Driving Mechanism)

Activate the corresponding operation command.

5.1.4. Earthing Operation from the Disconnected Position

7. Take the yellow slide in the yellow area to its right position (in this way the lever access for connecting the earthing switch is freed).

8. Insert the lever in the earthing switch lever access and turn 90° CLOCKWISE.

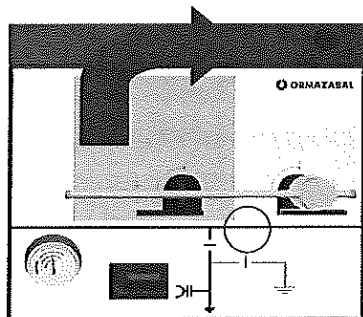

Figure 5.7: Lever Rotation Process

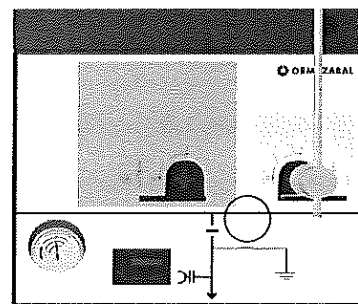

Figure 5.8: Connected Earthing Switch

5.2. BUSBAR SWITCH FUNCTION

5.2.1. Switch Connection Operation from the Disconnected Position

1. Take the black slide from the grey area to its left position (in this way the lever access for connecting the switch is freed).

2. Connection Operation:

2.1. Manual Operation (Driving Mechanism B)

Insert the lever in the Switch access and turn it 90° CLOCKWISE.

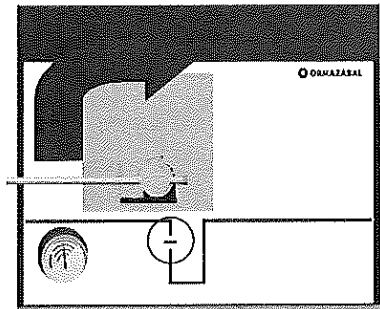

Figure 5.9: Lever Rotation Process

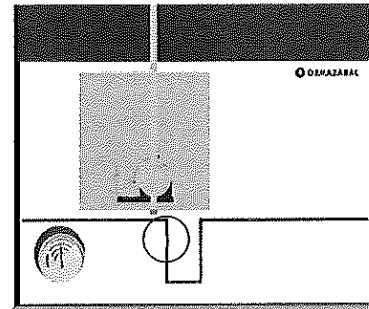

Figure 5.10: Connected Switch-Disconnecter

2.2. Motorised Operation (BM Driving Mechanism)

Activate the corresponding operation command.

5.2.2. Disconnection Operation from Connected Position

3. Take the black slide from the grey area to its left position (in this way the access for disconnecting the switch is freed).

4. Disconnection Operation

4.1. Manual Operation (B Driving Mechanism)

Insert the lever in the Switch access and turn it 90° ANTI CLOCKWISE.

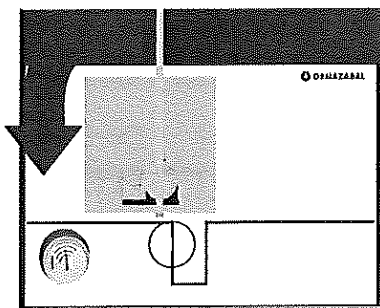

Figure 5.11: Lever Rotation Process

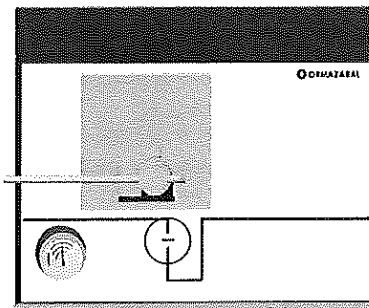

Figure 5.12: Disconnected Switch-Disconnecter

RECOMMENDATION: Although the figure shows the initial moment of the operation with the lever arm vertical, it is advisable to start with the lever arm horizontal and towards the right, in order to make the best use of the force applied by the operator.

4.2. Motorised Operation (BM Driving Mechanism)

Activate the corresponding operation command.



5.3. BUSBAR SWITCH WITH EARTHING CUBICLE

5.3.1. Disconnection Operation from the Earthing Position

1. Take the yellow slide to its right position (in this way the access for disconnecting the earthing switch is freed).
2. Insert the lever in the earthing switch lever access and turn 90° ANTICLOCKWISE.

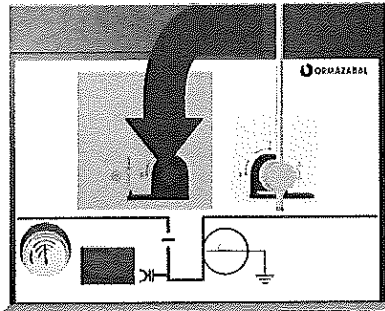

Figure 5.13: Lever Rotation Process

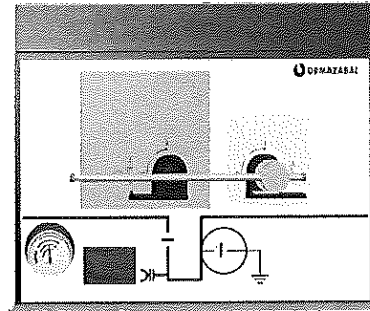

Figure 5.14: Disconnected Earthing Switch

RECOMMENDATION: Although the figure shows the initial moment of the operation with the lever arm vertical, it is advisable to start with the lever arm horizontal and towards the right, in order to make the best use of the force applied by the operator.

5.3.2. Switch Connection Operation from the Disconnected Position

3. Take the black slide from the grey area to its left position (in this way the lever access for connecting the switch is freed).

4. Connection Operation:

4.1. Manual Operation (B Driving Mechanism)

Insert the lever in the switch access (grey area) turn it 90° CLOCKWISE.

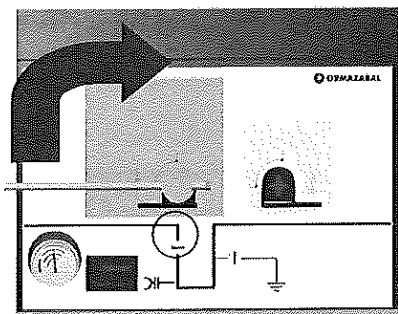

Figure 5.15: Lever Rotation Process

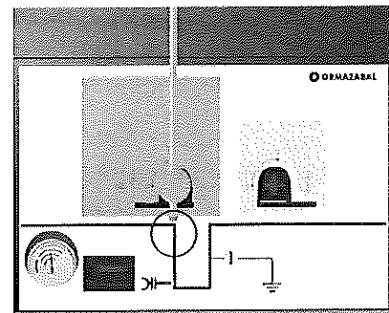

Figure 5.16: Connected Switch-Disconnect

4.2. Motorised Operation (BM Driving Mechanism)

Activate the corresponding operation command.

5.3.3. Disconnection Operation from Connected Position

5. Take the black slide from the grey area to its left position, in the same way as in the previous situation (in this way the access for connecting the switch is freed).

6. Disconnection Operation

6.1. Manual Operation (B Driving Mechanism)

Insert the lever in the switch access (grey area) turn it 90° ANTICLOCKWISE.

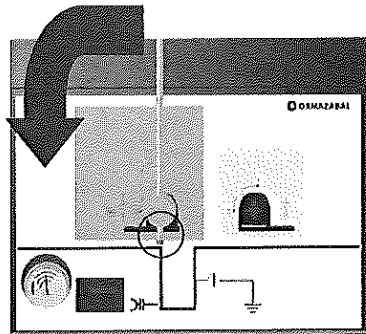

Figure 5.17: Lever Rotation Process

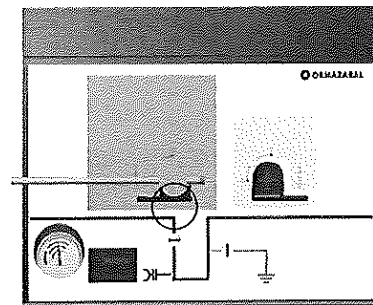

Figure 5.18: Disconnected Switch-Disconnecter

6.2. Motorised Operation (BM Driving Mechanism)

Activate the corresponding operation command.

5.3.4. Earthing Operation from the Disconnected Position

7. Take the yellow slide in the yellow area to its right position (in this way the lever access for connecting the earthing switch is freed).

8. Insert the lever in the earthing switch lever access and turn 90° CLOCKWISE.

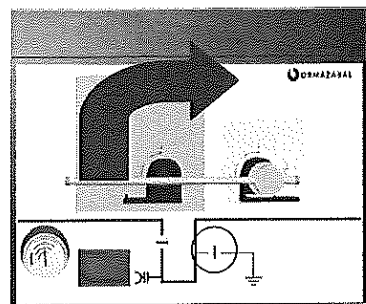

Figure 5.19: Lever Rotation Process

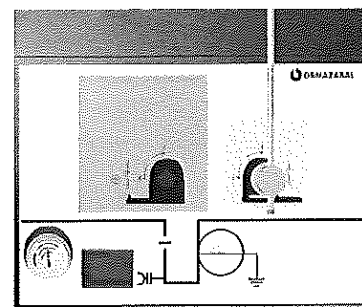

Figure 5.20: Connected Earthing Switch

5.4. FUSE PROTECTION CUBICLE

5.4.1. Disconnection Operation from the Earthing Position

1. Take the yellow slide to its right position (in this way the lever access for disconnecting the earthing switch is freed).
2. Insert the lever in the earthing switch lever access and turn 90° ANTICLOCKWISE.

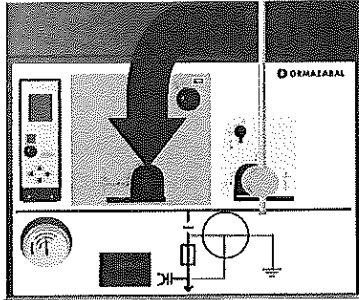

Figure 5.21: Lever Rotation Process

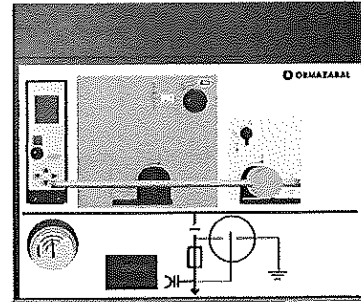

Figure 5.22: Disconnected Earthing Switch

RECOMMENDATION: Although the figure shows the initial moment of the operation with the lever arm vertical, it is advisable to start with the lever arm horizontal and towards the right, in order to make the best use of the force applied by the operator.

5.4.2. Connection Operation from the Disconnected Position

3. Take the black slide from the grey area to its left position (in this way the lever access for connecting the switch is freed)^[19].
4. Carry out the Connection Operation:

4.1. Manual Operation (BR Driving Mechanism)

Insert the lever in the switch access and turn it 90° CLOCKWISE.

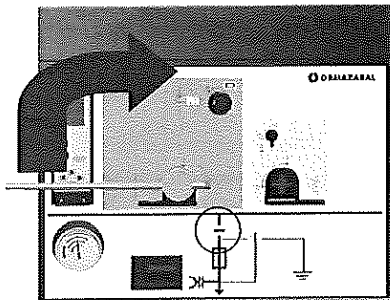

Figure 5.23: Lever Rotation Process

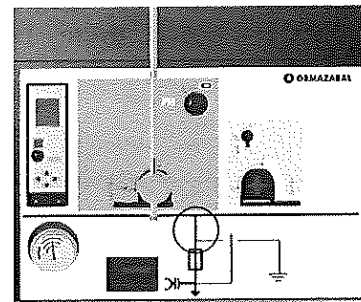

Figure 5.24: Connected Switch-Disconnect

^[19] The operation of the selector is the same as that of the feeder cubicles.

5.4.3. Spring Charging from the Connected Position

5. The spring charging must be carried out keeping the operating lever in the switch access.

⚠ IMPORTANT:

The access lever cannot be taken out of the switch after connecting it, until the Spring Loading operation has been carried out.

6. Turn the lever ANTICLOCKWISE.

7. Withdraw the switch's access lever.

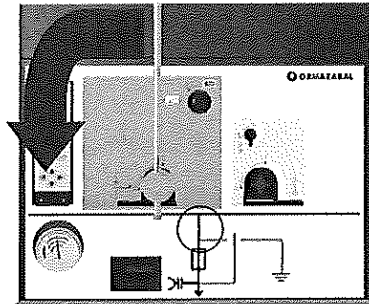

Figure 5.25: Lever Rotation Process

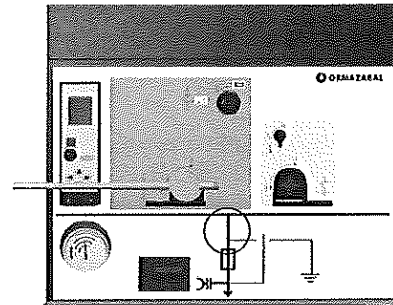

Figure 5.26: Switch Stays Connected

5.4.4. Disconnection Operation from Connected Position

8. With the switch closed and springs loaded.

9. Carry out the Disconnection Operation:

9.1. Manual Operation (BR Driving Mechanism)

Open the switch turning the triggering handle (f), in the position indicated in figure 5.27.

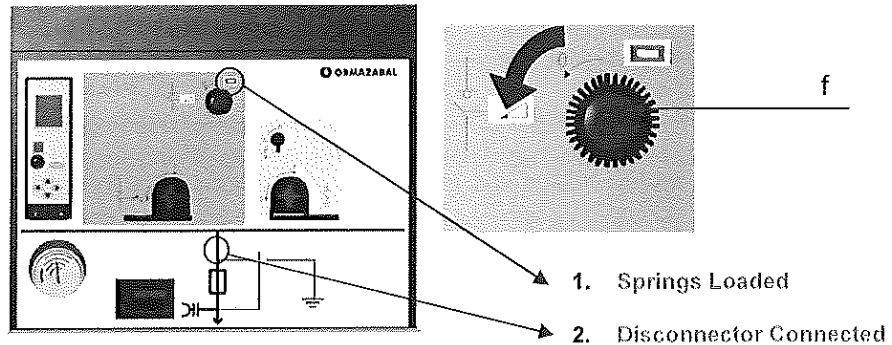

Figure 5.27: Disconnecter Disconnection Operation

ВЯРНО С
ОРИГИНАЛА
ММГ 23 ЕД С
СОФИЯ
ORMAZABAL

5.4.5. Earthing Operation from the Disconnected Position

10. Take the yellow slide to its right position (in this way the lever access for connecting the earthing switch is freed).

11. Insert the lever in the earthing switch access and turn 90° ANTICLOCKWISE.

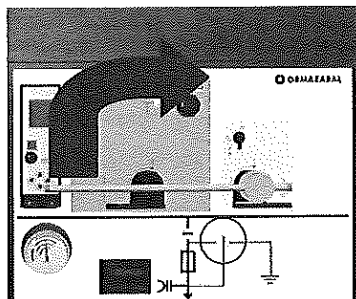

Figure 5.28: Lever Rotation Process

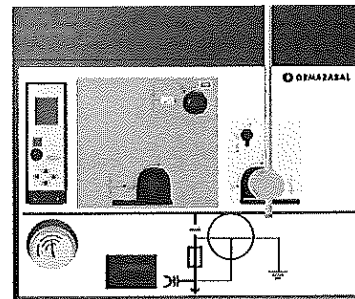

Figure 5.29: Connected Earthing Switch

5.4.6. Selection of Recommended Fuses

The fuses recommended for use in the CGMCOSMOS-P cubicle are defined according to the trials and tests carried out by the manufacturer. The following table shows the recommended fuse ratings according to the $U_r/P_{transf.}$:

U _r Line [kV]	U _r Cubicle [kV]	U _r Fuse [kV]	Transformer Rated Power WITHOUT OVERLOAD [kVA]																
			25	50	75	100	125	160	200	250	315	400	500	630	800	1000	1250	1600	2000
			Fuse Rated Current (A) IEC 60282-1																
10	24	6/12	6,3	10	16	16	20	20	25	31,5	40	50	63	63	80	100	160	200	250
13,5	24	10/24	6,3	6,3	10	16	16	20	20	25	31,5	40	50	63	63	80	100	-	-
15	24	10/24	6,3	6,3	10	16	16	16	20	20	25	31,5	40	50	63	80	80	160	-
20	24	10/24	6,3	6,3	6,3	10	16	16	16	20	20	25	31,5	40	50	50	63	80	125

- * Recommended SIBA fuses with middle-type striker, as per IEC 60282-1 (low power loss fuses).
- * The values for combined fuses, s/ IEC 62271-105 (IEC 60420) appear in bold type.
- * The switch-fuse assembly has been tested with heating under normal operating conditions as per IEC 60694.
- * There is a fuse holder trolley adapted to the size of the 6/12 kV fuses, which is 292 mm.
- * For ratings not in bold type the measurement is 442 mm.
- * All three fuses should be changed if any of the fuses blow.
- * For overload conditions in the transformer or the use of other makes of fuses, contact Ormazabal's Technical-Commercial department.

Transfer Current in accordance with IEC 60420 (IEC 62271-105):

U _r Fuse [kV]	U _r Cubicle [kV]	I _{transfer} [A]
12	24	2300
24	24	1600

5.4.7. Fuse Replacement Sequence

In order to access the fuse holders, remove the cover of the cable compartment; the earthing switch **must be closed**.

When it is possible to access the fuse holders, perform the following steps:

1. As this is a Combined Switch - Fuse cubicle, if any of the three fuses blows, the Switch - Disconnecter will automatically open.
2. The unmistakable signal for a blown fuse is indicated by the red stripe, which appears on the front of the driving mechanism compartment.

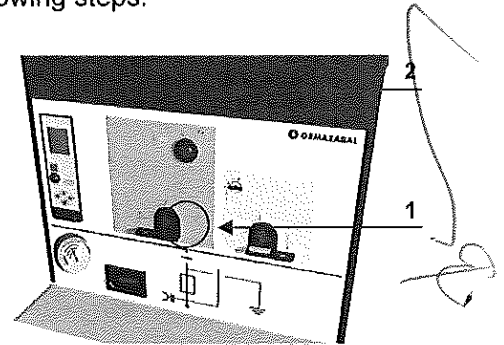

Figure 5.30: Triggering Indication

3. Close the Earthing Switch.

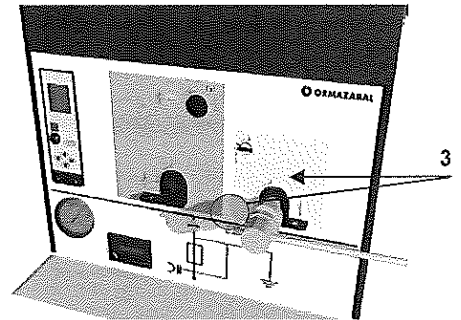

Figure 5.31: Close the Earthing switch

4. Open the access cover to the cable compartment.

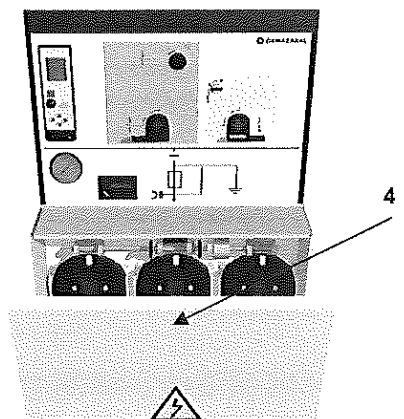
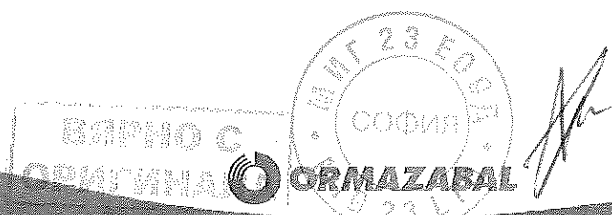

Figure 5.32: Cable compartment cover opening



9. Insert the fuse-holder trolley.

⚠ IMPORTANT:
 Before inserting the trolley, it is important to ensure that both the trolley and the inside of the fuse-holder are clean.

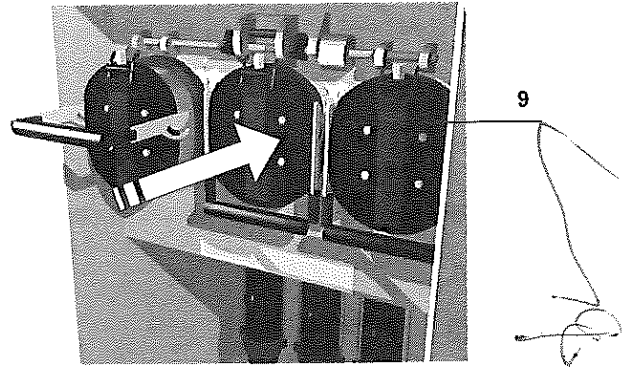

Figure 5.37: Fuse holder trolley insertion

10. Lower the fuse holder handle pushing it until it becomes "attached" to the safety trigger.

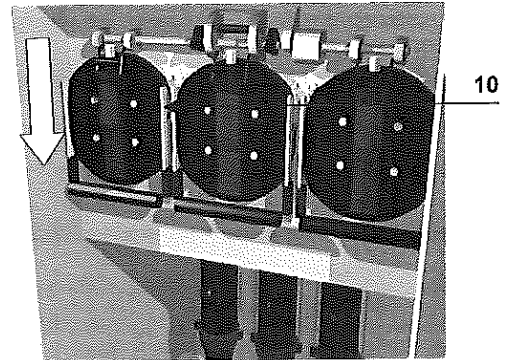

Figure 5.38: Close fuse holder

11. To close the cover, first make sure that the clip is correctly attached and that the fuse holder is correctly positioned. Position the access door to the fuse and cable compartment pulling it upwards until it comes out.

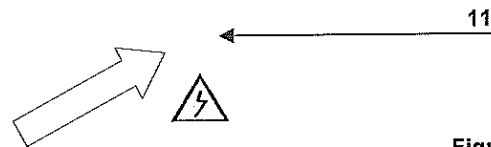
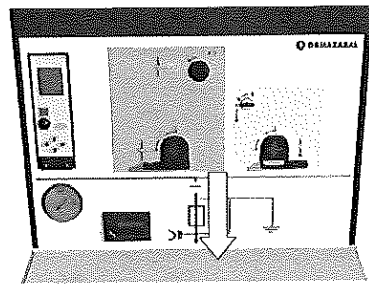
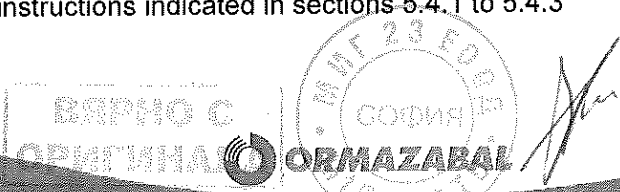

Figure 5.39: Cable compartment cover closing

12. Commission the cubicle following the instructions indicated in sections 5.4.1 to 5.4.3



5.5. CIRCUIT BREAKER CUBICLE

5.5.1. Disconnection Operation form the Earthing Position

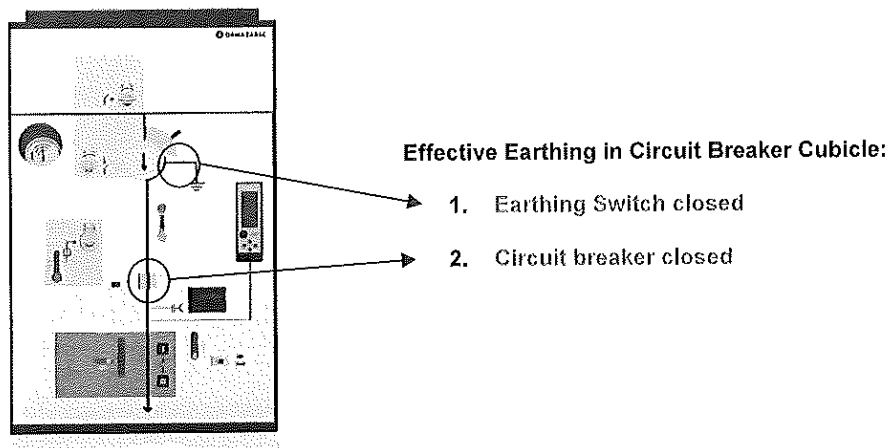

Figure 5.40: CGMCOSMOS-V Cubicle Earthing

▪ Step from the Earthing position to the "Ready for Earthing" position"

1. Open the circuit breaker pressing the opening button (a) and check the status indicator (b). The disconnecter is located in the "Ready for earthing" position".

"Ready for Earthing" Circuit Breaker Cubicle:

1. Earthing Switch closed
2. Circuit Breaker open

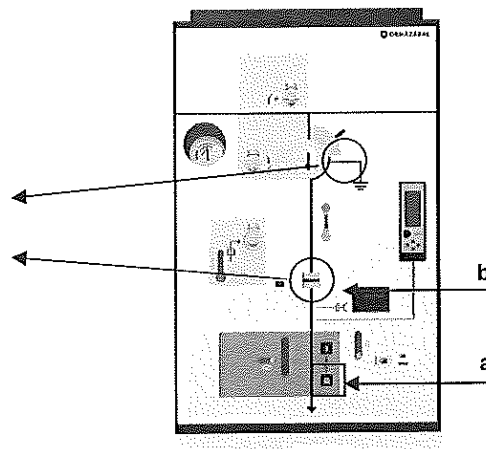

Figure 5.41: CGMCOSMOS-V Cubicle "Ready for Earthing"

⚠ ATTENTION!

If the springs are not charged, charge them manually. If the cubicle has the RAMV motor driven mechanism, this process is carried out automatically.

▪ Step from the "Ready for earthing" position to the Disconnected position

2. Start with the circuit breaker in its open position and the disconnector in the "Ready for Earthing" position.
3. Turn the locking part (c) and slide the knob down to remove the interlock plate. Turn it again to lock it into position (refer to figure 5.42).
4. Push the lever in from the RED side until the pin is released and turn ANTICLOCKWISE as far as it will go, to move the disconnector to the "Ready for earthing" position.

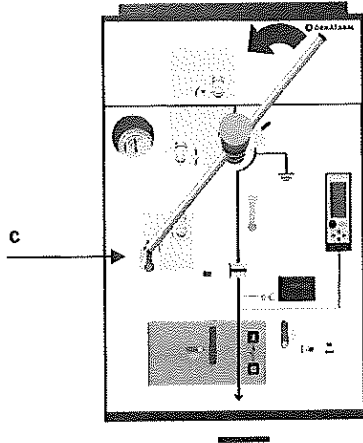

Figure 5.42: Lever Rotation Process

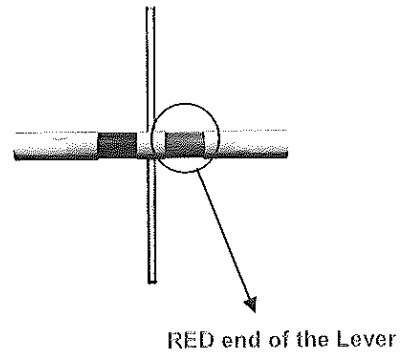

Figure 5.43: Switch-Disconnecter Lever

5. Withdraw the lever. Given its design, it is only possible to withdraw it in a safe position.
6. Turn the part again (c) to cancel the interlock.

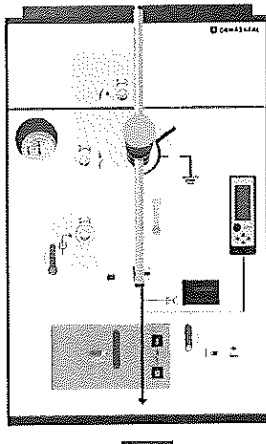

Figure 5.44: End Position of the Lever

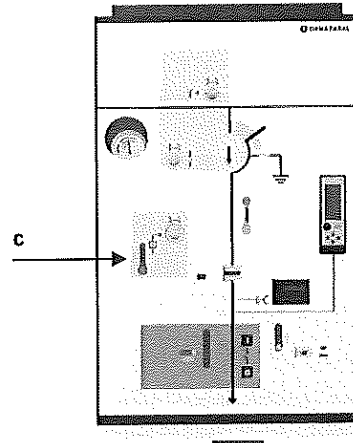

Figure 5.45: Disconnected Circuit Breaker Cubicle



5.5.2. Connection Operation from the Disconnected Position

7. Check that the circuit breaker is open.
8. Turn the locking part (c) and slide it down to remove the interlock plate (refer to figures). Turn it again to lock it in position.
9. Insert the lever from the BLACK side until the pin is released and turn ANTICLOCKWISE as far as it will go, to move the disconnector from disconnected to connected.

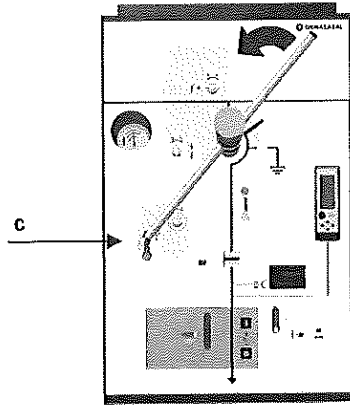

Figure 5.47: Lever Rotation Process

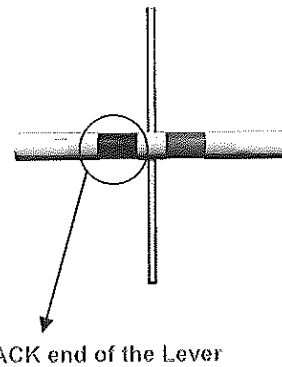

Figure 5.46: Disconnecter Lever

10. Pull the lever completely out to be able to close the circuit breaker. Due to its design, the lever can only be extracted in a safe position.
11. Turn the part (c) again to cancel the interlock (the interlock plate will move up)

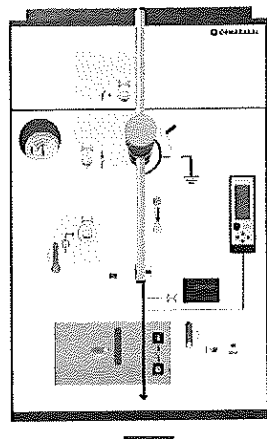

Figure 5.48: Final Disconnecter Position

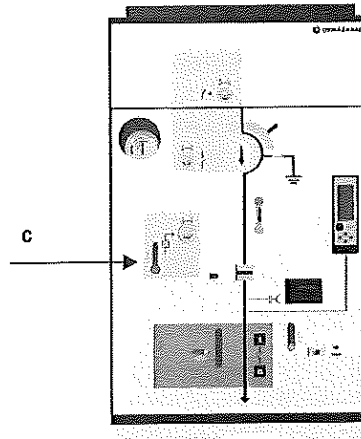

Figure 5.49: End Position of the Lever

12. Close the circuit breaker.

a) Manual driving mechanism (**RAV Driving Mechanism**):

Load springs, operating the loading lever (d) until it is indicated that the closing spring has tightened → Spring load (e).

To close the circuit breaker, press the close button (f).

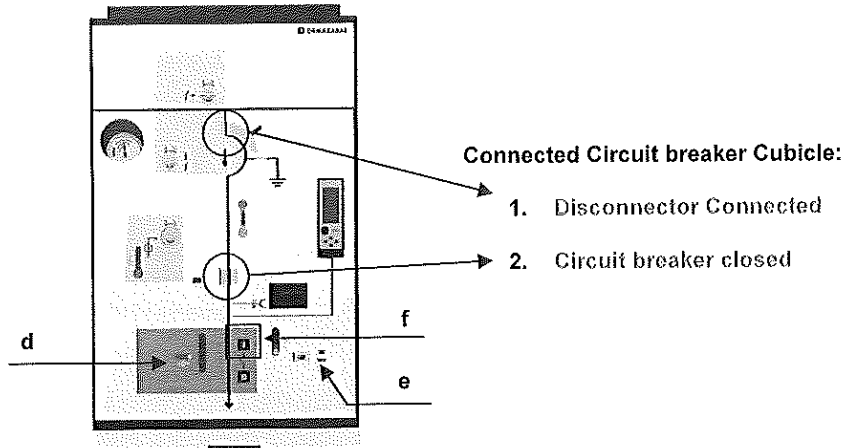

Figure 5.50: Connected CGMCOSMOS-V Cubicle

b) Motor driven mechanism (**RAMV Driving Mechanism**):

Press the circuit breaker close button (f).

13. Check for the presence of voltage (ekorVPIS)

5.5.3. Disconnection Operation from Connected Position

The starting conditions are: Closed circuit breaker and closed earthing switch (refer to figure 5.50).

1. Open the circuit breaker pressing the opening button (a) and check the status indicator (b)

⚠ ATTENTION:

To open the circuit breaker, check the spring loading indication (e), and if it is slack, tighten the spring, with the manual operation^[20]. If the cubicle has the RAMV motor driven mechanism, this process is carried out automatically.

^[20] Refer to point 12 in the commissioning process of the CGMCOSMOS-V cubicle



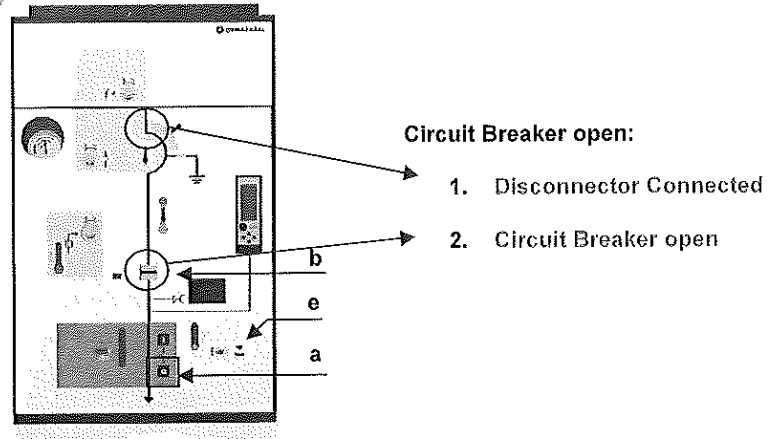

Figure 5.51: Circuit Breaker Opening

2. Check that there is no voltage.
3. Check that the circuit breaker is open.
4. Turn the locking part (c) and slide it down to remove the interlock plate (refer to figure 5.52). Turn it again to lock it in position.
5. Insert the lever from the BLACK side until the pin is released and turn CLOCKWISE as far as it will go, to move the disconnecter from connected to disconnected.

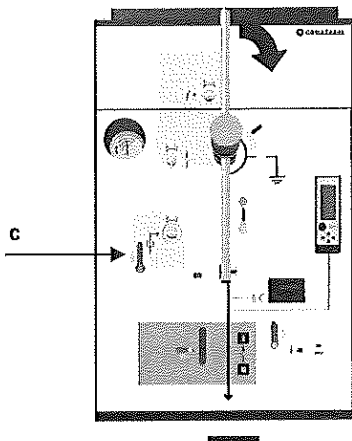

Figure 5.52: Lever Rotation Process

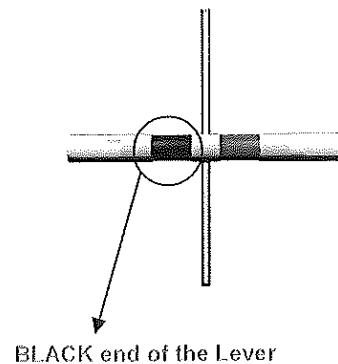

Figure 5.53: Switch-Disconnecter Lever

6. Pull the lever completely out to be able to close the circuit breaker. Due to its design, the lever can only be extracted in a safe position.
7. Turn the part (c) again to cancel the interlock (the interlock plate will move up)

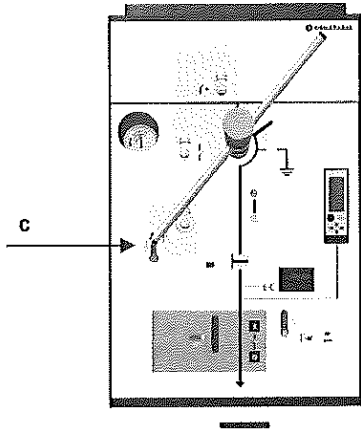

Figure 5.54: End Position of the Lever

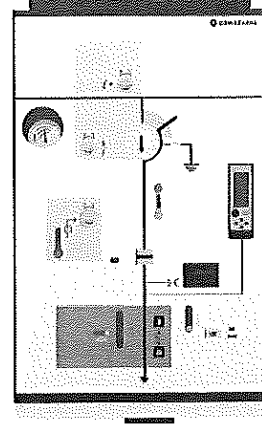

Figure 5.55: Disconnected Circuit Breaker Cubicle

5.5.4. Earthing Operation from the Disconnected Position

- Step from the "Ready for earthing" position to the Disconnected position

8. Start with the circuit breaker in its open position and the disconnector in the "Ready for Earthing" position.
9. Turn the locking part (c) and slide the knob down to remove the interlock plate. Turn it again to lock it into position (refer to figure 5.56).
10. Push the lever in from the RED side until the pin is released and turn CLOCKWISE as far as it will go, to move the "Ready for earthing" disconnector to the disconnected position.

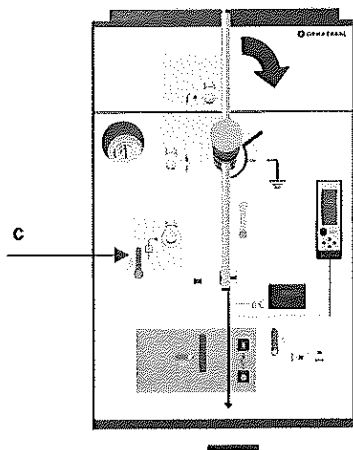

Figure 5.56: Lever Rotation Process

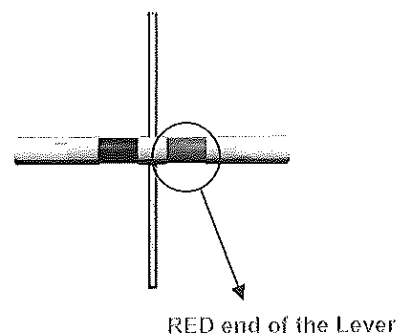

Figure 5.57: Switch-Disconnecter Lever



11. Withdraw the lever. Given its design, it is only possible to withdraw it in a safe position.
12. Turn the part again (b) to cancel the interlock.

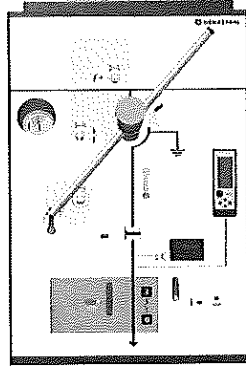

Figure 5.58: End Position of the Lever

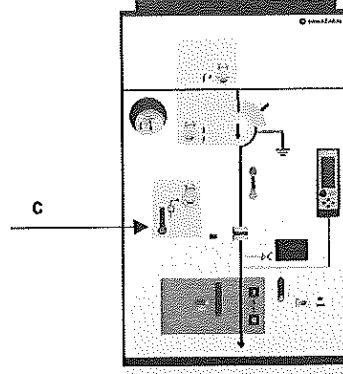

Figure 5.59: "Ready for Earthing" Circuit Breaker Cubicle

⚠ ATTENTION:

For the cable to be properly earthed, the circuit breaker must be closed, as described below.

▪ **Step from the "Ready for Earthing" position to the Earthed Position**

13. Close the circuit breaker pressing the opening button (f) and check the status indicator (b). The disconnecter is Earthed.

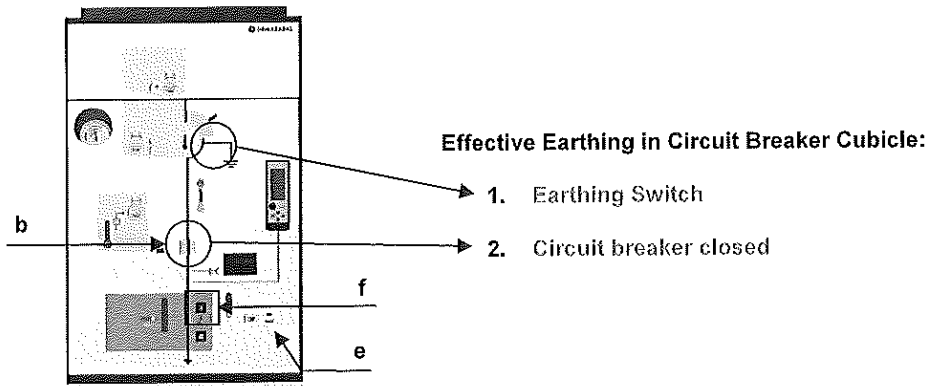

Figure 5.60: CGMCOSMOS-V Cubicle Earthing

14. Check that there is no voltage.

⚠ ATTENTION:

To be able to close the circuit breaker, check the spring loading indication (f), and if it is slack, tighten the spring, with the manual operation ^[21].

For voltage-free work, the earthing switch closed position must be interlocked either with a padlock or with a lock.

^[21] Refer to point 12 of the CGMCOSMOS-V cubicle's commissioning sequence.

5.6. BUSBAR RISER FUNCTIONAL UNIT WITH EARTHING

5.6.1. Disconnection Operation form the Earthing Position

1. Take the yellow slide to its right position (in this way the access for disconnecting the earthing switch is freed).
2. Insert the lever in the Earthing Switch access and turn 90° ANTICLOCKWISE.

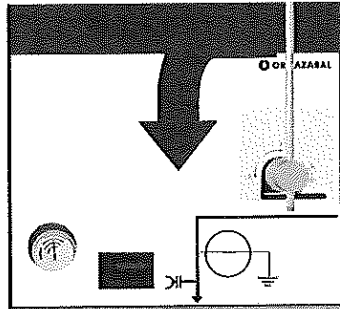

Figure 5.61: Lever Rotation Process

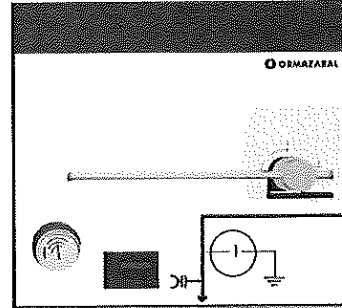

Figure 5.62: Disconnected Earthing Switch

RECOMMENDATION: Although the figure shows the initial moment of the operation with the lever arm vertical, it is advisable to start with the lever arm horizontal and towards the right, in order to make the best use of the force applied by the operator.

5.6.2. Earthing Operation from the Disconnected Position

3. Take the yellow slide to its right position (in this way the lever access for connecting the earthing switch is freed).
4. Insert the lever in the Earthing Switch access and turn 90° CLOCKWISE.

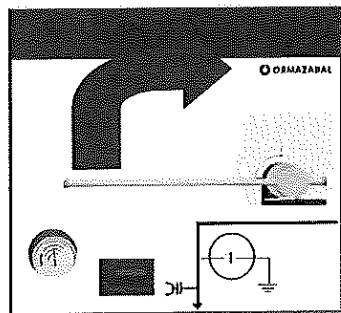

Figure 5.63: Lever Rotation Process

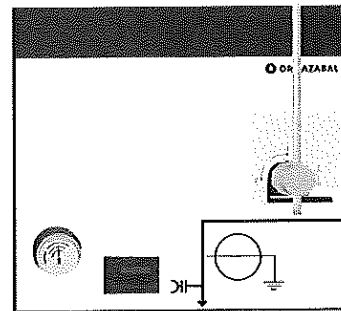

Figure 5.64: Connected Earthing Switch

ВЕРНО С
ОРИГИНАЛ
МАЙ 23 ЕО 01
КОДИЯ
ORMAZABAL

5.7. POSITIONING THE ACCESS COVER TO CABLE COMPARTMENT

5.7.1. Standard Bases

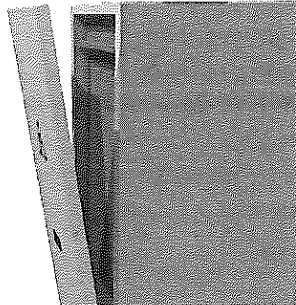

Figure 5.1

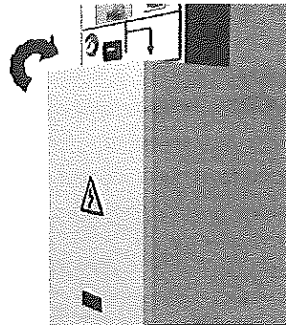

Figure 5.2

Rest the cover on the lower section of the base and push until it fits into its upper part.

5.7.2. Bases for Internal Arc in Cable Compartment

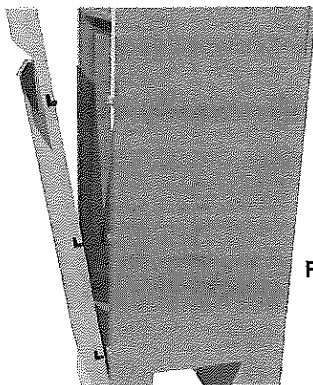

Figure 5.3

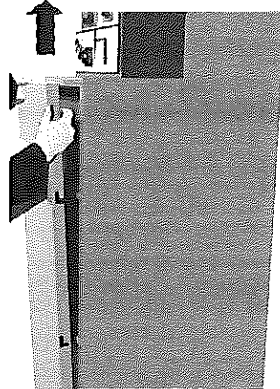

Figure 5.4

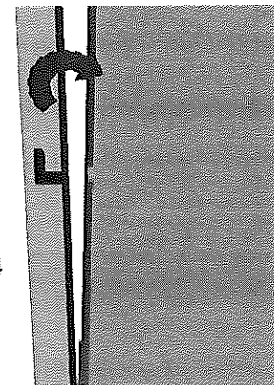

Figure 5.5

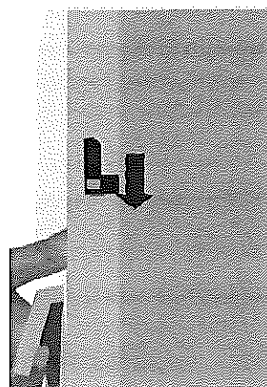

Figure 5.6

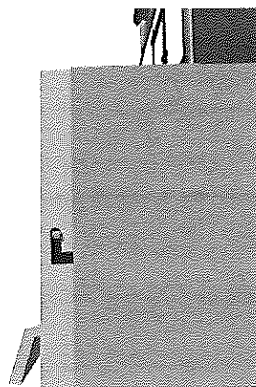

Figure 5.7

Rest the cover on the lower section of the base, lift it slightly until it fits into the base's side inserts, lower it whilst pushing until it fits into its upper part.

Perform the sequence the other way around to unlock the access cover to the cable compartment.

In CGMCOSMOS-P cubicles with fuse protection, on interlocking the access door to the cable compartment the linkage reset is operated **directly** causing it to autocharge.

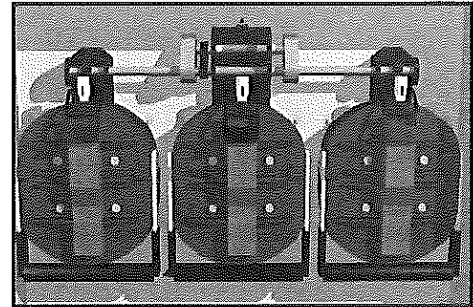

Figure 5.8: Triggering Linkage in CGMCOSMOS-P cubicles

5.8. ASSEMBLY SEQUENCE FOR THE BASE INTERNAL ARC TERMINAL COVER BOX IN THE CABLE COMPARTMENT TYPE 21 kA - 1 s

5.8.1. Withdrawal

1. Open and withdraw the access cover to the cable compartment according to section 5.7.1.
2. Slightly lift the box guard using upper part's handle.
3. Slowly extract the box until it reaches the end of the guide rail.

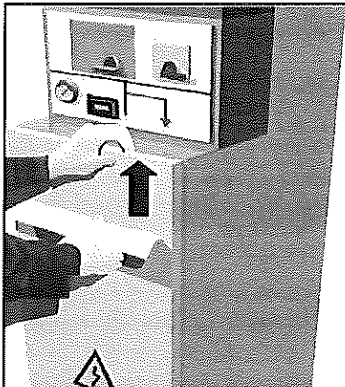

Figure 5.9

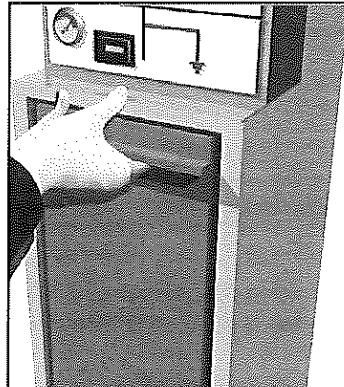

Figure 5.10

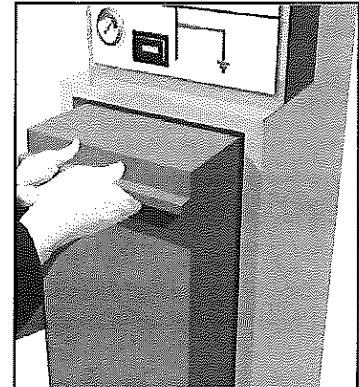

Figure 5.11

4. Holding the upper part of the box with one hand and the lower part with the other, lower the box carefully onto the floor paying attention to its weight.

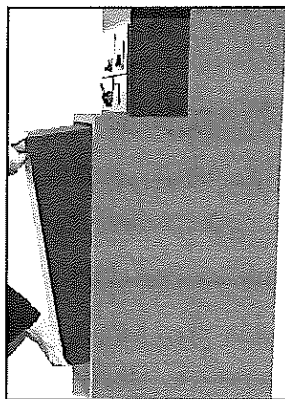

Figure 5.12

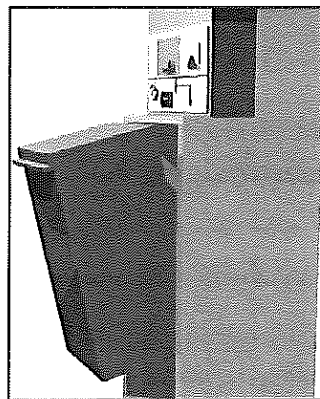

Figure 5.13

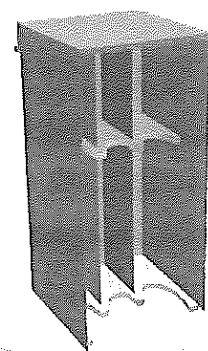

Figure 5.14: Detail of the Base terminal cover box

5.8.2. Positioning

1. Lift the box and make it fit into the guide rail in the base.

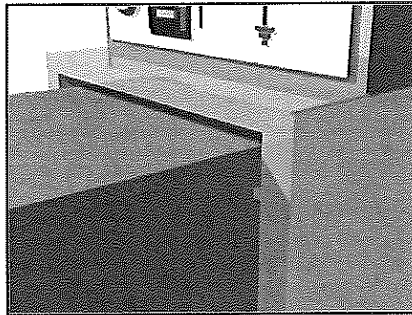

Figure 5.15: Box positioning on the rails

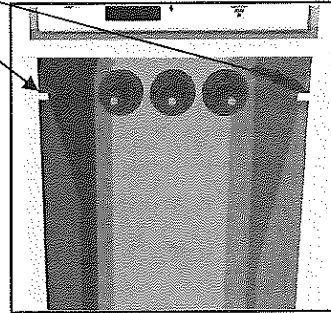

Figure 5.16: Detail guide rails

2. Push it until it comes to a stop.

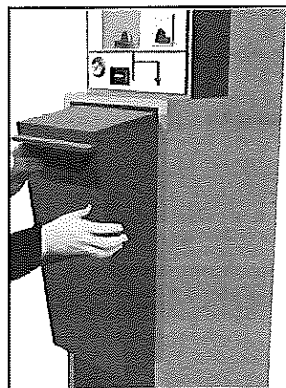

Figure 5.17: Slightly tilt to insert

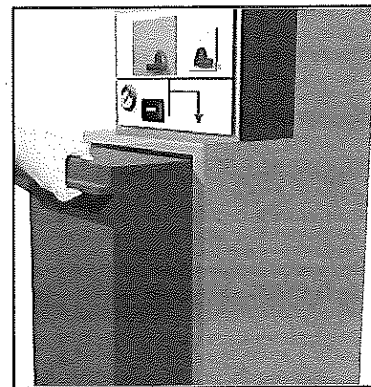

Figure 5.18: Pushing the box inside

3. Finally push until it fits into place and position the upper handle.

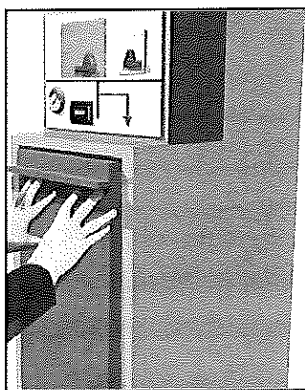

Figure 5.19



Figure 5.20

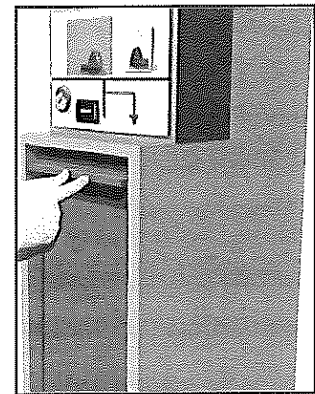

Figure 5.21

4. Place the access cover to the cable compartment.

5.9. INTERLOCKS

5.9.1. Padlocking

Each operating shaft is padlockable with up to three standard padlocks, with a maximum handle diameter of 8 mm.

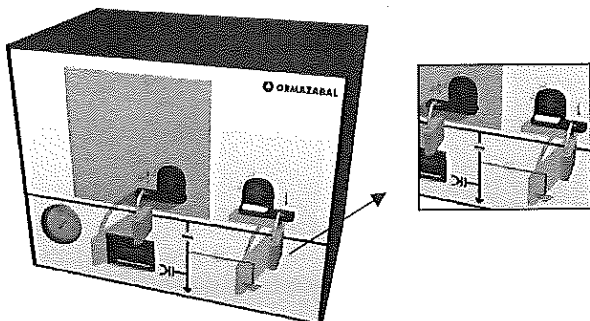

Figure 5.22: Padlocking in Feeder Cubicles

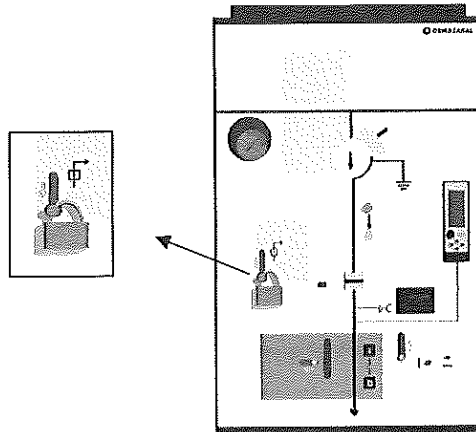

Figure 5.23: Padlocking in Circuit Breaker Cubicles

5.9.2. Locking

The cubicles are prepared for optionally incorporating sets of open and closed locks.

Examples of Locks (optional):

- **Lock 1: Earthing switch, interlocked in open position.** This prevents the switch from being put in the "earthed / ready for earthing" position until the key for the low-voltage switch lock is recovered, but does allow it to be switched to the main position.
- **Lock 2: Earthing switch, interlocked in closed position (MUST ALWAYS BE INTERLOCKED for working under de-energized conditions).** This prevents someone from inadvertently opening the switch, removing the earthing from the cable.
- **Lock 3: Earthing switch Interlocked in Open position.** This prevents the earthing switch from being switched to the "connected" position, but does allow the switch to be operated to the "earthed / ready for earthing" position.

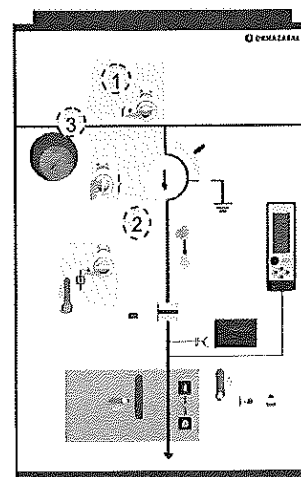

Figure 5.24: Locking in the CGMCOSMOS-V cubicle

Interlocking Lock 1 and Lock 3 together will prevent the switch from being moved from the "disconnected" position.



6. MAINTENANCE

The active parts of the switching apparatus and main circuit of the CGMCOSMOS cubicles do not need to be inspected or maintained, as they are completely insulated in SF₆ gas and therefore free from any influence on the external environment. The E2-class electrical endurance tests guarantee free maintenance of the interrupting components.

Under the operating conditions specified in IEC 60694, the operating mechanism of the CGMCOSMOS system cubicles does not require any kind of lubrication to ensure proper operation according to the service conditions specified in IEC 60694, over its expected service life.

These mechanisms must be inspected in extreme usage conditions (dust, salt, pollution). It is advisable to carry out at least one operating during these inspections.

The components manufactured in galvanised sheet metal have been subjected to a painting process to guarantee their performance against corrosion. If they are scratched, dented or similar, they must be repaired to prevent corrosion.

6.1. VOLTAGE PRESENCE INDICATOR TEST

To carry out a test on the ekorVPIS voltage presence indicator, connect it to a 230 V_{ac} supply source. To do this, the cubicle should be disconnected and with 4 mm terminals apply the voltage between the phase test point to be checked and the ground test point. There is no polarity for the 230 V_{ac} socket, and therefore either the phase or the neutral can be connected. The indicator is working properly if there is a luminous flashing signal. To test the indicator properly, this check must be carried out in the three phases.

The ekorVPIS indicator can be replaced if necessary. To do so, the two screws on the upper right and lower left side of the indicator must be removed. Subsequently, the indicator can be removed from the base without having to deenergize the cubicle.

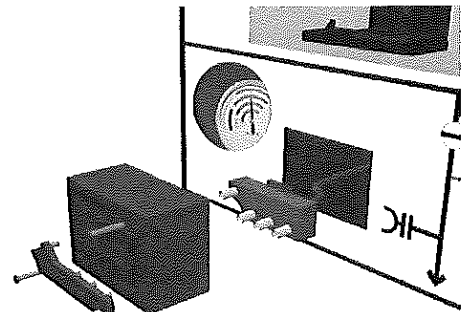

Figure 6.1: ekorVPIS connection mode

6.2. EARTHING PREVENTION ACOUSTIC ALARM CHECK

The proper functionality of the ekorSAS can be tested by connecting the ekorVPIS voltage presence indicator to 230 V_{ac} with 4-mm terminals placed in the indicator between the ground test point and the phase L1 test point. Auxiliary power is maintained for 5 minutes and after this time, the lever is placed in the earthing axis for switching, the alarm starts and stays on for at least 30 seconds. It stops when the lever is pulled out.

If necessary, the **ekorSAS** can be replaced since it is connected to the associated components with two PCB connectors for friction adjustment:

- One 3-pin connector (polarized) for the Voltage Presence Indicator
- One 2-pin connector for the lever microswitch

The process is as follows:

- Loosen the screws holding the upper trim and remove it.
- Remove the operating mechanism cover.
- Lightly press the ekorSAS's lower attaching tabs to remove it.
- Loosen the two connectors and replace the broken unit, then reconnect it to the lever microswitch (2-pin connector) and to the voltage indicator (polarized 3-pin connector).

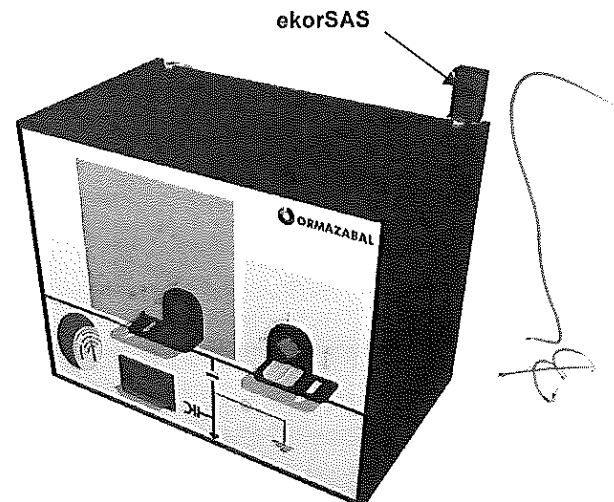

Figure 6.2: ekorSAS device positioning in CGMCOSMOS cubicles

➤ **ekorSAS replacement in CGMCOSMOS-V cubicles:**

The process is as follows:

- Loosen the screws holding the upper trim and remove it.
- Remove the operating mechanism cover.
- Unscrew the ekorSAS's lock screws to remove it.
- Loosen the two connectors and replace the unit, then reconnect it to the lever microswitch (2-pin connector) and to the voltage indicator (polarized 3-pin connector).

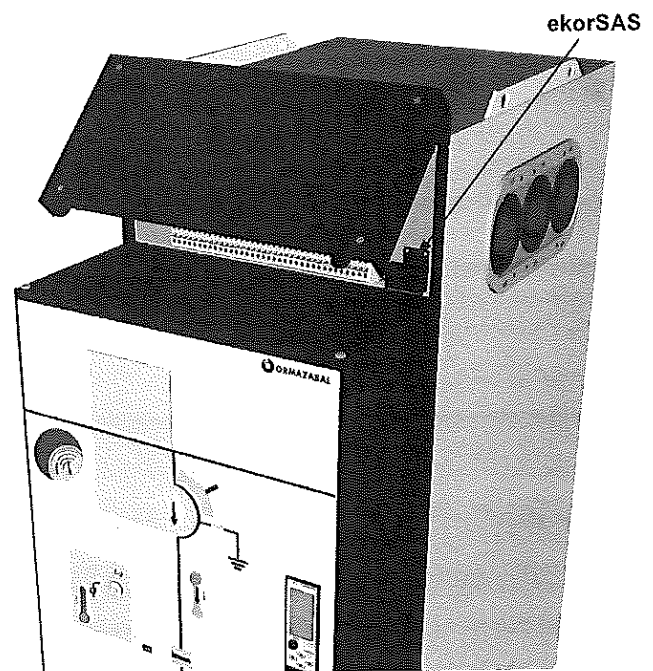
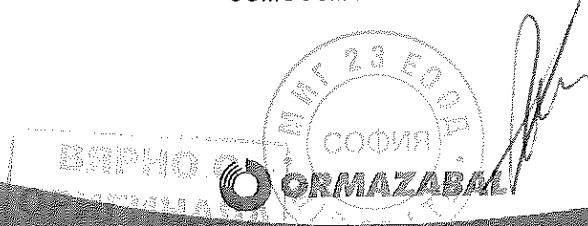

Figure 6.3: ekorSAS device positioning in CGMCOSMOS-V cubicles



➤ **ekorSAS connection:**

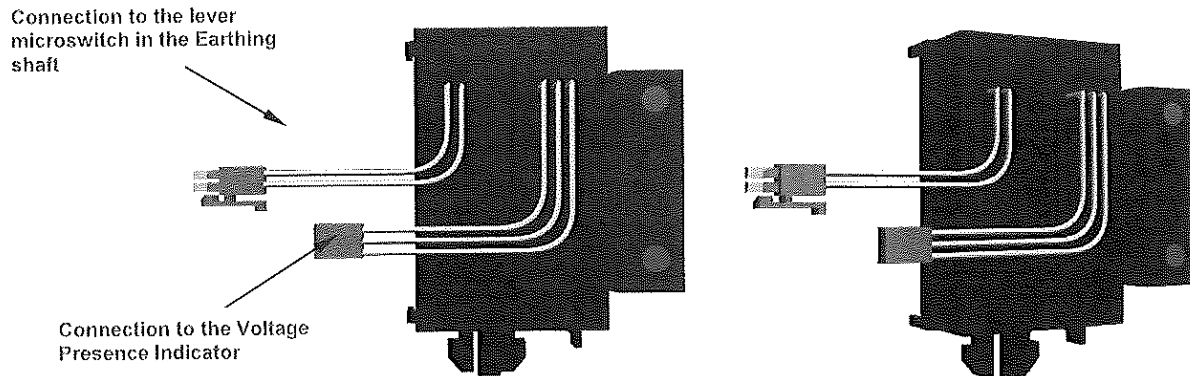

Figure 6.4: ekorSAS connection

6.3. CGMCOSMOS-V CUBICLE PREVENTATIVE MAINTENANCE

The driving mechanisms and other components outside the gas tank may require preventative maintenance, and the intervals will depend on the existing environmental conditions (aggressive environments, dust, extreme temperatures, etc.) and must be established according to the experience and responsibility of the installation.

Maintenance must be carried out every 5 years or 2000 operating cycles, except when considered otherwise by the user together with Ormazabal's Technical – Commercial Department according to the exploitation conditions.

The drive system, considered low maintenance, has a mechanical endurance of 10 000 operations.

- Solvents used with pressurised air must not be used for general cleaning.
- The adjustment components such as: limiting shaft, shock absorber, plugs, nuts and bolts, which have been sealed, must not be manipulated.

The **estimated time** for state of repair check is approximately **one hour** and it is necessary to have the following tools ready beforehand:

- Loctite A-270
- Torque Wrench
- "Super-Lube" lubricant spray
- Antirust spray

Preventative maintenance must be carried out in accordance with the following conditions:

- Circuit breaker open and earthing switch connected.
- Auxiliary circuit supply cut.
- Disconnection of remote control equipments.
- Check opening and closing springs are unloaded.

6.3.1. Visual Inspection

- Check that the interlocking circlips, split pins and interlock retracting pins are correctly in place and have not become loose or detached, paying special attention to those pertaining to the main movement transmission chain.
- Check that the adjustment sealed components are unchanged, in particular the limiting shaft, and the securing nuts of the phase transmission and output shaft.
- Take care that the connection cables are not close to transmission movement areas.
- If the superficial protections are rusty or dusty, get the products indicated above, paying special attention to the parts inside the chassis. transmissions, ratchets and cams, taking into consideration operationability and aesthetics.
- Bear in mind the number of operations on the meter, the installation date and the location characteristics and, if this is the first service, even previous corrective maintenance, for new inspections.

Estimated visual inspection duration: 10 minutes

6.3.2. Verification Checks

The condition of the equipment must be checked carrying out 2 manual operations:

First:

- Manual spring loading.
- Check that it holds on the closing ratchet in a stable position and that the opening retainer "returns" to below the retainer shaft quickly and with a minimum play of 2 mm.
- Close the circuit breaker.
- Check that the opening retaining is stable.
- Open the circuit breaker with the pushbutton station.

Second:

- Load closing spring.
- Close
- Load closing spring
- Open
- Close and Open

If the cubicle is motorised, two motorised operations with coil (or coils) must be carried out

First:

- Load with motorisation
- Check M0 and M1 microswitches



- Check if the NC contacts are open with its control lever activated.
 - Close with closing coil.
 - Open with opening coil.

Second:

- Load closing spring
- Close with coil.
- Load closing spring.
- Open-Close and Open with coils.

If the cubicle has the ekorRPG protection unit, carry out the following check:

- Energise the relay with 220 V_{ac} (if it is not already energised).
- Bridge terminals G4 and G5 from the relay in accordance with the electrical diagram of the ekorRPG protection unit
- Check that the circuit breaker opens.
- Carry out 2 opening operations.

Estimated time: 20 minutes

6.3.3. Securing Nuts and Bolts Tightening Check

Ensure that all the nuts and bolts are not loose. Pay special attention to the bolted joints supporting the frame, chassis support to the cubicle structure and those, which form the driving mechanism structure.

It is necessary to check (manually with a standard spanner) if the connection needs the application of the assigned tightening torque.

If any loose bolts are found, use Loctite A-270, and apply the rated torque corresponding to its metrics.

Estimated checking time: 10 minutes

6.3.4. Checking Settings

The driving mechanism is set by the manufacturer for the whole service life. Therefore, the settings **which should not be manipulated** are sealed.

Limiting shaft main setting:

- Check that it is not loose or without seal. Do not handle except in the presence of Ormazabal's Technical – Commercial department.

Shock absorber setting:

- Check that this is sealed.

Transmission to phases:

- It is never manipulated. Check that it is sealed.

6.3.5. Lubrification

Lubricate all turning points of: shafts, bearings, bushings, rollers, and generally any sliding components.

Use Super-Lube Teflon-based lubricant spray, with an application tube to ensure the product is applied where it will be effective.

If any non-functional rust is observed on any component, apply antirust spray.

Do not use aggressive liquids such as corrosive solvents, etc., nor pressure air to remove small particles or accumulated dust.

Estimated time: 10 minutes

If any corrections have been made to the driving mechanism, it is necessary to carry out the check operations (section 6.4.4) of the entire cycle twice^[22].

Otherwise, a few operations are sufficient to evenly lubricate the components.

^[22] Ormazabal's Technical – Commercial Department must be notified with a report of any corrections carried out for analysis.

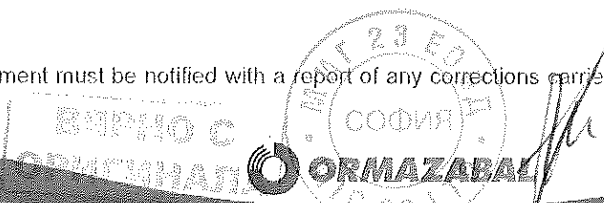

7. ADDITIONAL INFORMATION

7.1. SPARE PARTS AND ACCESSORIES

Although the cubicles are designed for a service life according to the IEC 60298 standard, some components may have to be replaced and installed for different reasons. The following is a list of these components:

- ekorVPIS voltage presence indicators
- Operating Mechanism
- ekorSAS Acoustic Alarm
- Levers

In the event of it being necessary to change any of the auxiliary parts indicated, the relevant order for the spares kit shall be made and the corresponding instructions followed in the corresponding documentation.

Note: Some spare parts and accessories require being installed by specialised staff. Contact Ormazabal's Technical – Commercial Department.

7.2. ENVIRONMENTAL INFORMATION

7.2.1. Sulphur Hexafluoride SF₆^[23]

The CGMCOSMOS cubicles are defined as a pressurised sealed system containing sulphur hexafluoride (SF₆).

SF₆ is included in the Kyoto Protocol's list of greenhouse effect gases list. SF₆ has a GWP of 22,200 units.

At the end of the product's life, the SF₆ content must be recovered for treatment and recycling, preventing it from being freed into the atmosphere. The extraction and handling of the SF₆ must be carried out by specialised staff^[24].

^[23] This information is indicated on a label on the equipment.

^[24] If in doubt, contact Ormazabal's Technical – Commercial department.

7.3. ELECTRICAL CHARACTERISTICS OF THE B DRIVING MECHANISMS

7.3.1. Coils

The electrical ratings of coils and the auxiliary contacts for the switch position are as follows:

ELECTRICAL CHARACTERISTICS			
TRIP COIL	Rated voltage	24 V _{cc} , 48 V _{cc} 230 V _{ac}	110 V _{cc}
	Maximum consumption	80 W	
	Internal insulation	2 kV	
SIGNALLING CONTACTS	Switch position signalling contacts	1 NAC 1 NAC + 2 NA	2 NA
	Rated voltage	250 V _{ac}	
	Rated current	16 A	

The BR operating mechanism allows up to 2 NO + 2 NC contacts to be added for switch status and 2 NO contacts for the earthing switch status.

7.3.2. Motorisations

The electrical characteristics are as follows:

ELECTRICAL CHARACTERISTICS		
MOTORISATIONS	Rated voltage	24 V _{cc} , 48 V _{cc} , 110 V _{cc} and 125 V _{cc} 220 V _{ac}
	Peak current	<5 A
	Motor switching time	3 s
	Switch signalling contacts	2 NA + 2 NC
SIGNALLING CONTACTS	Signalling contacts for earthing	2 NA
	Rated voltage	250 V _{ac}
	Rated current	16 A

Note: The electrical diagrams for each type of cubicle are supplied with the order documentation.

ВЕРНО С
ОРИГИНАЛА



ORMAZABAL



B.2

TECHNICAL – COMMERCIAL DEPARTMENT:

www.ormazabal.com



www

CGMCOSMOS-2LP

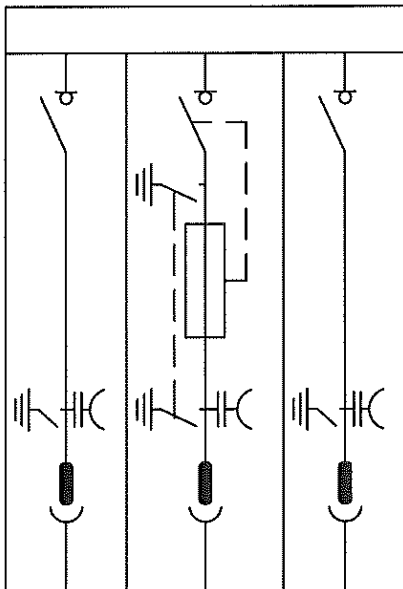

Handwritten mark resembling a stylized 'S' or '3'.

Handwritten signature or initials.

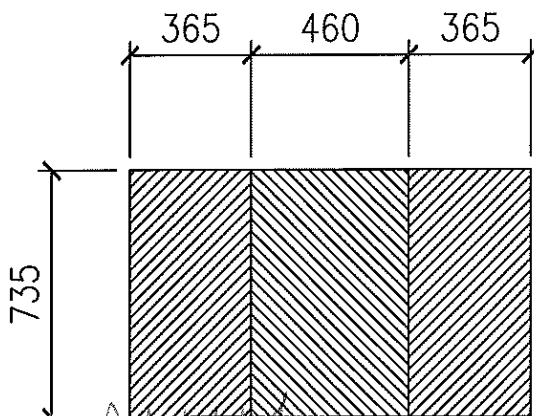
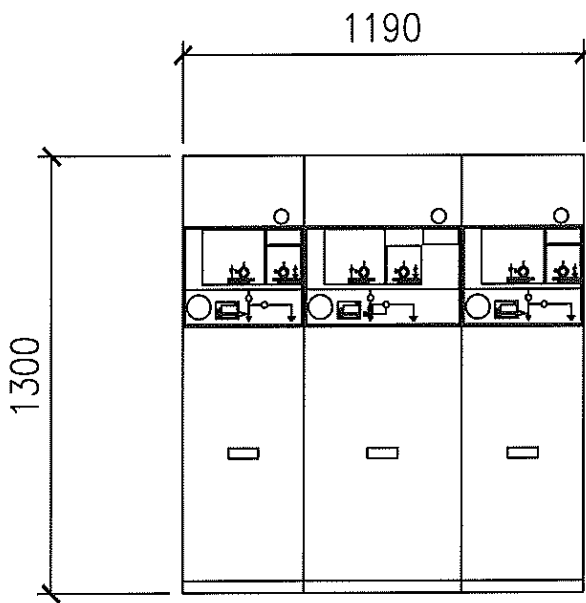

ММГ 23 ЕООД
СОФИЯ
ММГ 23 ЛТД
ВЯРНО С
ОРИГИНАЛА

Handwritten signature.

3

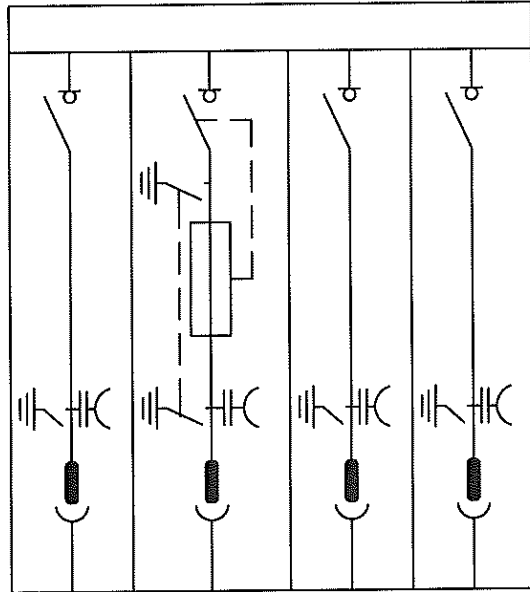

Handwritten signature or mark.

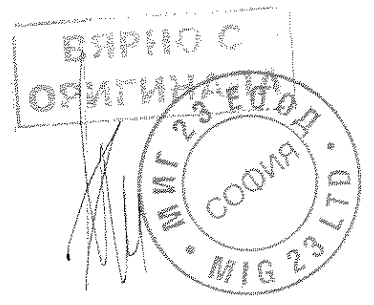
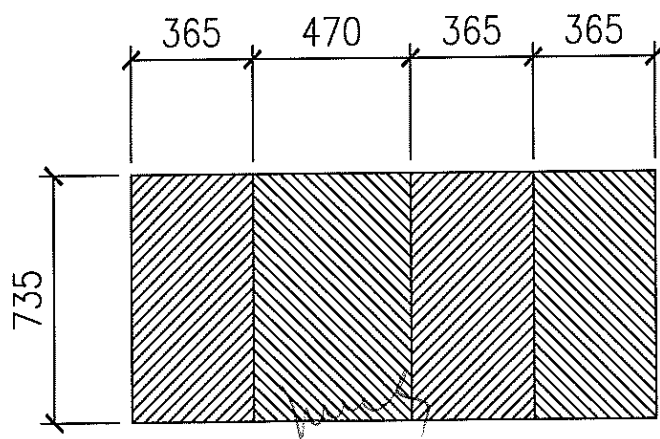
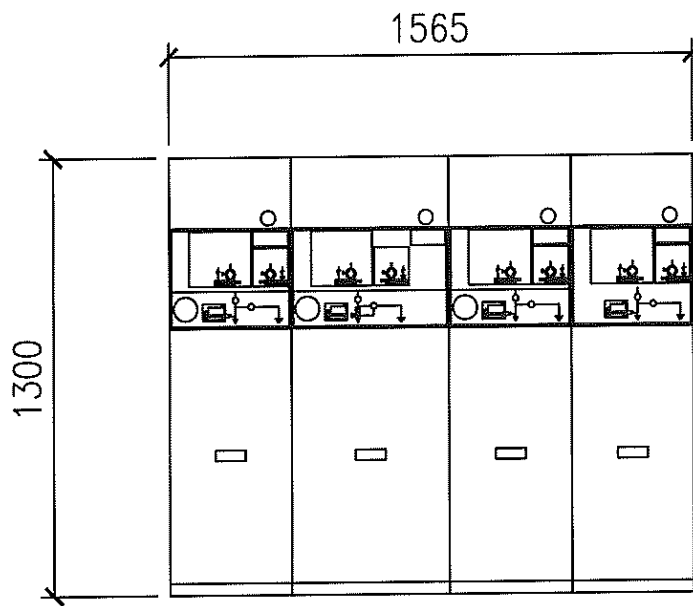

Cubicles assembly: components

WASTE	CUBICLE PART	TYPE OF WASTE	MANAGE
Iron (Scrap Iron)	Cable Compartment and Frontal Sheets	No Dangerous Waste	Authorized recycler
	Gas Tank		
	Driving Mechanism		
	Switch Disconnecter / Earth Switch		
Copper	Cable Compartment and Frontal Sheets	No Dangerous Waste	Authorized recycler
	Gas Tank		
	Switch Disconnecter / Earth Switch		
	Connections (Bushing and Female Bushing) (*)		
Steel	Cable Compartment and Frontal Sheets	No Dangerous Waste	Authorized recycler
	Gas Tank		
Aluminium (**)	Driving Mechanism	No Dangerous Waste	Authorized recycler
	Gas Tank		
Plastics in General	Switch Disconnecter / Earth Switch	Industrial Inert Waste	Authorized recycler
	Cable Compartment and Frontal Sheets		
	Gas Tank		
	Switch Disconnecter / Earth Switch (**)		
	Driving Mechanism		
	Fuse Holder (**)		
	Connections (Bushing and Female Bushing) (*)		
Wood	Package	No Dangerous Waste Inert Gas	Authorized recycler
Sulphur Hexafluoride (SF ₆)	Gas Tank		Authorized recycler

(*) Female bushings and male bushings have inside copper components, and because of the difficulty to separate them from the resin they are considered as inert industrial waste, together with plastics.

(**) Elements are managed as general scraps due to their diverse material composition and the difficulty on their separation.

ВЯРНО С
ОРИГИНАЛА

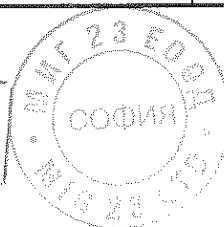

Обработка на отпадъците от отделните компоненти на КРУ

Отпадъци	Част на панела	Тип на отпадъците	Обработка
Желязо (скрап)	Кабелен отсек и преден капак	Няма опасни отпадъци	Оторизирана фирма за преработка
	Казан за елегаз		
	Задвижващ механизъм		
	Мощностен разединител / Земен нож		
Мед	Кабелен отсек и преден капак	Няма опасни отпадъци	Оторизирана фирма за преработка
	Казан за елегаз		
	Мощностен разединител / Земен нож		
	Връзки (мъжки и женски проходни изолатори) (*)		
Стомана	Кабелен отсек и преден капак	Няма опасни отпадъци	Оторизирана фирма за преработка
	Казан за елегаз		
	Задвижващ механизъм		
	Казан за елегаз		
Алуминий (**)	Мощностен разединител / Земен нож	Няма опасни отпадъци	Оторизирана фирма за преработка
	Кабелен отсек и преден капак		
	Казан за елегаз		
	Мощностен разединител / Земен нож		
Пластмаси - общо	Кабелен отсек и преден капак	Индустриални инертни отпадъци	Оторизирана фирма за преработка
	Казан за елегаз		
	Мощностен разединител / Земен нож		
	Задвижващ механизъм		
Дърво	Стойки за предпазители (***)	Няма опасни отпадъци	Оторизирана фирма за преработка
	Връзки (мъжки и женски проходни изолатори) (*)		
	Опаковка		
	Казан за елегаз		
Елегаз (SF6)		Инертен газ	Оторизирана фирма за преработка

(*) Женските и мъжките проходни изолатори имат отвъртре медни компоненти, но понеже е много трудно да бъдат отделени от лятата смола, те се счита за инертни индустриални отпадъци, заедно с пластмасите.

(**) Елементите се обработват като общи отпадъци поради тяхната разнородна структура на материала и трудността при тяхното разделяне.

ОРМАЗАБАЛ

Обработка на панелите в края на експлоатационния живот

Берсия 1 2008-01-01

ВАРНО С ОРИГИНАЛА

B-POWER

Списък на протоколи от типови изпитания на КРУ CGCOSMOS, производство на ORMAZABAL

Сериен No	Описание	Стандарт	Акредитирана лаборатория
24507001	Изпитание на вътрешно к.с. с електрическа дъга, класификация IAC AFL 16 kA/1 s	IEC 62271-200, Annex A	KEMA
31745101	Изпитание на вътрешно к.с. с електрическа дъга, класификация IAC AFL 20/21 kA/1 s	IEC 62271-200, Annex A	KEMA
31756402	Изпитание на вътрешно к.с. с електрическа дъга, класификация IAC AFL 20/21 kA/1 s	IEC 62271-200, Annex A	KEMA
K12520001	Изпитание на вътрешно к.с. с електрическа дъга, класификация IAC AF 20 kA/1 s	IEC 62271-200, Annex A	KEMA
31009211-M5	Изпитание на вътрешно к.с. с електрическа дъга, класификация IAC AFL 21 kA/1 s	IEC 62271-200	ORMAZABAL Corporate Technology
31009211-M6	Изпитание на вътрешно к.с. с електрическа дъга, класификация IAC AFL 21 kA/1 s	IEC 62271-200	ORMAZABAL Corporate Technology

ВЯРНО С
ОРИГИНАЛА

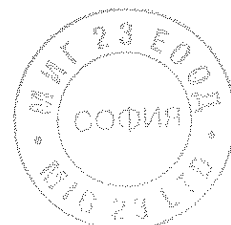

B



REPORT OF PERFORMANCE

304-07

Handwritten mark resembling a stylized 'A' or 'B' with a vertical line.

APPARATUS The busbar and three-phase three-position switch compartment of an SF₆-insulated metal-enclosed ring main unit cubicle

TYPE CGMCosmos-2LP-F **SERIAL No.** 24507001

24 kV – 630 A – 16 kA – 50/60 Hz

CLIENT Ormazabal Distribución Secundaria, Igorre (Vizcaya), Spain

MANUFACTURER Ormazabal Distribución Secundaria, Igorre (Vizcaya), Spain

TESTED BY KEMA HIGH-POWER LABORATORY
Utrechtseweg 310 - 6812 AR Arnhem - The Netherlands

DATE(S) OF TESTS 14 February 2007

TEST SPECIFICATION The tests have been carried out in accordance with the client's instructions. Test procedure and test parameters were based on IEC 62271-200, Annex A

This report consists of 22 sheets in total.

This report falls under the scope of the accreditation certificate I. 020 of the Dutch Council for Accreditation. See information sheet (page 2).

© Copyright: Only integral reproduction of this report, or reproductions of this page accompanied by any page(s) on which are stated the endorsed ratings of the apparatus tested, are permitted without written permission from KEMA. Electronic copies in e.g. PDF-format or scanned version of this report may be available and have the status "for information only". The sealed and bound version of the report is the only valid version.

KEMA Nedriana B.V.

P.G.A. Bus CONTROL 10/10/2008
KEMA T&D Testing Services
Managing Director

Arnhem, 19 July 2007

ВЯРНО С
ОРИГИНАЛА

Handwritten signature

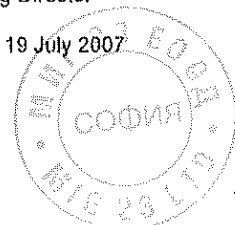

Handwritten signature



1 Certificate

A Certificate contains a record of a series of type tests carried out strictly in accordance with a recognized standard. The equipment tested has fulfilled the requirements of this standard and the relevant ratings assigned by the manufacturer are endorsed by KEMA. The Certificate is applicable only to the equipment tested. KEMA is responsible for the validity and the contents of the Certificate.

The responsibility for conformity of any apparatus having the same designation as the one tested rests with the manufacturer. The Certificate contains the essential drawings and a description of the equipment tested.

Detailed rules are given in KEMA's Certification procedure.

2 Report of Performance

A Report of Performance contains a record of one or more tests which have been carried out according to the client's instructions. These tests are not necessarily in accordance with a recognized standard. The test results do not verify ratings of the test object.

KEMA issues three types of Reports of Performance:

2.1 The tests have been carried out strictly in accordance with The apparatus has complied with the relevant requirements.

This sentence will appear on the front page of a Report of Performance if the tests have been performed in accordance with a recognized standard, but the series of tests does not completely fulfil the requirements for a Certificate of Compliance (for example, if the number of test duties is not a complete series of type tests). The Report contains verified drawings and a description of the equipment tested. Detailed rules are given in KEMA's Certification procedure. The condition of the test object after the tests is assessed and recorded in the Report.

2.2 The tests have been carried out in accordance with the client's instructions. Test procedure and test parameters were based on

This sentence will appear on the front page of a Report of Performance if the number of tests, the test procedure and the test parameters are based on a recognized standard and related to the ratings assigned by the manufacturer. If the apparatus does not pass the tests such behaviour will be mentioned on the front sheet. Verification of the drawings (if submitted) and assessment of the condition after the tests is only done on the client's request.

2.3 The tests have been carried out according to the client's instructions.

This sentence will appear on the front page of a Report of Performance if the tests, test procedure and/or test parameters are not in accordance with a recognized standard.

3 Standards

When reference is made to a standard, and the date of issue is not stated, this applies to the latest issue, including amendments which have been officially published prior to the date of the tests.

4 Official and uncontrolled test documents

The official test documents of KEMA High-Power Laboratory are issued in bound form. Uncontrolled copies may be provided as loose sheets or as a digital file for convenience of reproduction by the client. The copyright has to be respected at all times.

5 Accuracy of measurement

In the table of test results the measured quantities are given in three digits. This method of presentation does not indicate an accuracy. The guaranteed uncertainty in the figures mentioned, taking into account the total measuring system, is less than 5%, unless mentioned otherwise.

6 Qualified by RvA (Dutch Council for Accreditation)

KEMA High-Power Laboratory and High-Voltage Laboratory have been entered in the RvA-register for laboratories under resp. Nrs. L 020 and L 218 for the testing services as defined in the Field of Accreditation.

The accreditation is carried out in accordance with ISO/IEC 17025.



CONTROL: 1180X1 0/2008
RvA F 076

ВЯРНО С
ОРИГИНАЛА

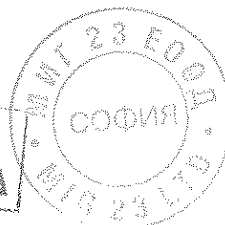

W



304-07

TABLE OF CONTENTS

Page 3

Handwritten mark resembling a checkmark or signature.

TABLE OF CONTENTS:

INFORMATION SHEET2

IDENTIFICATION OF THE APPARATUS TESTED.....4
 Ratings assigned by the manufacturer4
 Description of apparatus tested4
 List of drawings4

GENERAL INFORMATION.....5
 The tests were witnessed by.....5
 The tests were observed by.....5
 Notes.....5

LEGEND.....6

DUTY: Checking of the prospective current.....7
 Test circuit.....8
 Test 070214-4009.....9

DUTY: Internal fault test.....10
 Test circuit.....11
 Photographs before test.....12
 Test 070214-4010.....14

CONDITION / INSPECTION AFTER TEST15
 Photograph after test16

DRAWINGS.....17

CONTROL: 10/10/2008

Version: 1

ВЯРНО С
ОРИГИНАЛА

Handwritten signature below the stamp.

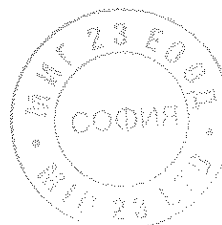

Handwritten signature next to the stamp.



304-07

IDENTIFICATION OF THE APPARATUS TESTED

Page 4

RATINGS ASSIGNED BY THE MANUFACTURER

Voltage	24 kV
Number of poles	3
Frequency	50/60 Hz
Normal current:	
Busbar	630 A
Feeder circuit	630 A
Short-time withstand current:	Peak withstand current:
Internal arc current 16 kA for 1 s	41,6 kA
Classification IAC	AFL

DESCRIPTION OF APPARATUS TESTED

The busbar and three-phase three-position switch compartment of an SF₆-insulated metal-enclosed ring main unit cubicle

Minimum pressure for insulation at 20 °C	0,115 MPa
Maximum pressure for insulation at 20 °C	0,13 MPa

LIST OF DRAWINGS

*The manufacturer has guaranteed that the equipment submitted for tests has been manufactured in accordance with the following drawings.
KEMA has verified that these drawings adequately represent the equipment tested.
The following drawings are included in this report:*

- DOC-2561 Rev. 01
- DOC-2562 Rev. 01
- DOC-2563 Rev. 01
- DOC-2567 Rev. 01
- DOC-2572 Rev. 01
- DOC-2200 Rev. 01

CONTROL: 10/10/2008

Version: 1





304-07

GENERAL INFORMATION

Page 6

THE TESTS WERE WITNESSED BY

Name

Company

Casado, J.M.
Osuna, J.A.
Rodríguez, J.
Sainz De La Maza, N.
Sebastián Martín, S.

Ormazabal Distribución Secundaria,
Igorre (Vizcaya), Spain



THE TESTS WERE OBSERVED BY

Name

Company

Jorna, R.E.

KEMA,
Arnhem, The Netherlands

NOTES

- The tests were recorded on regular-speed video and on high-speed video.
- During tests assembly was filled with air at rated pressure.

CONTROL: 10/10/2008

Version: 1

ВЯРНО С
ОРИГИНАЛА

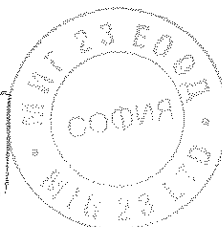

Handwritten signature



REPORT OF PERFORMANCE

308-09

APPARATUS The cable compartment of a three-phase SF₆-insulated metal-enclosed switchgear assembly

TYPE CGM Cosmos L **SERIAL No.** 31745101

24 kV – 630 A – 20⁽¹⁾ kA – 50/60 Hz

⁽¹⁾ See note on page 4.

CLIENT Ormazabal Distribución Secundaria, Igorre (Vizcaya), Spain

MANUFACTURER Ormazabal Distribución Secundaria, Igorre (Vizcaya), Spain

TESTED BY KEMA HIGH-POWER LABORATORY
Utrechtseweg 310 - 6812 AR Arnhem - The Netherlands

DATE(S) OF TESTS 12 March 2009

TEST SPECIFICATION The tests have been carried out in accordance with the client's instructions. Test procedure and test parameters were based on IEC 62271-200, Annex A.

This report applies only to the apparatus tested. The responsibility for conformity of any apparatus having the same designations with that tested rests with the Manufacturer.

This report consists of 31 sheets in total.

This report falls under the scope of the accreditation certificate L 020 of the Dutch Council for Accreditation. See information sheet (page 2).

© Copyright: Only integral reproduction of this report is permitted without written permission from KEMA. Electronic copies in e.g. PDF-format or scanned version of this report may be available and have the status "for information only". The sealed and bound version of the report is the only valid version.

KEMA Nederland B.V.
на основание чл. 2 от ЗЗЛД

KEMA T&D Testing Services
Managing Director

Arnhem, 25 June 2009

Printed by cci 14/11/2013

ВЯРНО С
ОРИГИНАЛА

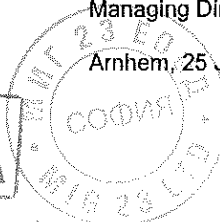



1 Certificate

A Certificate contains a record of a series of type tests carried out strictly in accordance with a recognized standard. The equipment tested has fulfilled the requirements of this standard and the relevant ratings assigned by the manufacturer are endorsed by KEMA. The Certificate is applicable only to the equipment tested. KEMA is responsible for the validity and the contents of the Certificate.

The responsibility for conformity of any apparatus having the same designation as the one tested rests with the manufacturer. The Certificate contains the essential drawings and a description of the equipment tested.

Detailed rules are given in KEMA's Certification procedure.

2 Report of Performance

A Report of Performance contains a record of one or more tests which have been carried out according to the client's instructions. These tests are not necessarily in accordance with a recognized standard. The test results do not verify ratings of the test object.

KEMA issues three types of Reports of Performance:

2.1 *The tests have been carried out strictly in accordance with The apparatus has complied with the relevant requirements.*

This sentence will appear on the front page of a Report of Performance if the tests have been performed in accordance with a recognized standard, but the series of tests does not completely fulfil the requirements for a Certificate of Compliance (for example, if the number of test duties is not a complete series of type tests). The Report contains verified drawings and a description of the equipment tested. Detailed rules are given in KEMA's Certification procedure. The condition of the test object after the tests is assessed and recorded in the Report.

2.2 *The tests have been carried out in accordance with the client's instructions. Test procedure and test parameters were based on*

This sentence will appear on the front page of a Report of Performance if the number of tests, the test procedure and the test parameters are based on a recognized standard and related to the ratings assigned by the manufacturer. If the apparatus does not pass the tests such behaviour will be mentioned on the front sheet. Verification of the drawings (if submitted) and assessment of the condition after the tests is only done on the client's request.

2.3 *The tests have been carried out according to the client's instructions.*

This sentence will appear on the front page of a Report of Performance if the tests, test procedure and/or test parameters are not in accordance with a recognized standard.

3 Standards

When reference is made to a standard, and the date of issue is not stated, this applies to the latest issue, including amendments which have been officially published prior to the date of the tests.

4 Official and uncontrolled test documents

The official test documents of KEMA High-Power Laboratory are issued in bound form. Uncontrolled copies may be provided as loose sheets or as a digital file for convenience of reproduction by the client. The copyright has to be respected at all times.

5 Accuracy of measurement

In the table of test results the measured quantities are given in three digits. This method of presentation does not indicate an accuracy. The guaranteed uncertainty in the figures mentioned, taking into account the total measuring system, is less than 5%, unless mentioned otherwise.

6 Qualified by RvA (Dutch Council for Accreditation)

KEMA High-Power Laboratory and High-Voltage Laboratory have been entered in the RvA-register for laboratories under resp. Nrs. L 020 and L 218 for the testing services as defined in the Field of Accreditation.

The accreditation is carried out in accordance with ISO/IEC 17025.

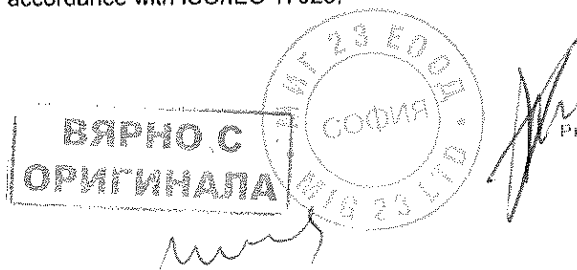

3



308-09

TABLE OF CONTENTS

Page 3

Handwritten mark resembling a checkmark or signature.

TABLE OF CONTENTS:

INFORMATION SHEET2

IDENTIFICATION OF THE APPARATUS TESTED.....4
 Ratings assigned by the manufacturer4
 Description of apparatus tested4
 List of drawings4

GENERAL INFORMATION.....5
 The tests were witnessed by.....5
 The tests were observed by.....5
 Notes.....5

LEGEND6

SUMMARY OF TESTS7

DUTY: Checking of the prospective current.....12
 Test circuit.....13
 Tests 090312-400214

DUTY: Checking of the prospective current.....15
 Test circuit.....16
 Tests 090312-400417

DUTY: Internal fault test.....18
 Test circuit.....19
 Photographs before test.....20
 Test 090312-4009.....22

CONDITION / INSPECTION AFTER TEST23
 Photograph after test24

DRAWINGS.....25

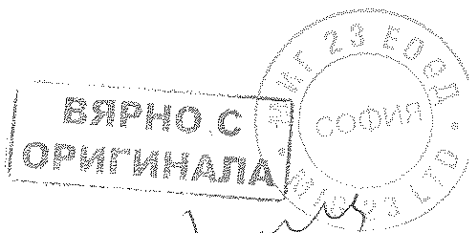

Handwritten signature



308-09

IDENTIFICATION OF THE APPARATUS TESTED

Page 4

RATINGS ASSIGNED BY THE MANUFACTURER

Voltage	24 kV
Number of poles	3
Frequency	50/60 Hz

Normal current:

Busbar	630 A
Feeder circuit	630 A

Short-time withstand current:

Main circuit	20/21 kA for 1 s
Earthing circuit	20/21 kA for 1 s
Internal arc current	20/21 ⁽¹⁾ kA for 1 s

Peak withstand current:

55 kA
55 kA
55 kA

Pressure for insulation SF₆ at 20 °C

0,13 MPa

Classification IAC

AFL

⁽¹⁾ IEC rating / Rating assigned by the manufacturer.

On request of the client the tests in this report have been based on a short-circuit current of 21 kA.

DESCRIPTION OF APPARATUS TESTED

The cable compartment of a three-phase SF₆-insulated metal-enclosed switchgear assembly.

Minimum pressure for interruption at 20 °C

0,115 MPa

Maximum pressure for interruption at 20 °C

0,13 MPa

LIST OF DRAWINGS

On request of the manufacturer the following drawings are included in this report.

KEMA has not verified these drawings.

- DOC-2685 Rev. 02
- DOC-2864 Rev. 01
- DOC-2930 Rev. 01
- DOC-2879 Rev. 01
- DOC-2866 Rev. 01
- DOC-2867 Rev. 01
- DOC-2868 Rev. 01

Version: 1



Printed by cci 14/11/2013



308-09

GENERAL INFORMATION

Page 5

THE TESTS WERE WITNESSED BY

Name

Sebastián Martín, S.

Company

Ormazabal Distribución Secundaria,
Igorre (Vizcaya), Spain

THE TESTS WERE OBSERVED BY

Name

de Vries, G.J.

Company

KEMA,
Arnhem, The Netherlands

NOTES

For test purposes equipment filled with air at rated pressure for insulation instead of SF₆ gas.

The tests were recorded on regular-speed video and on high-speed video.

ВЯРНО С
ОРИГИНАЛА

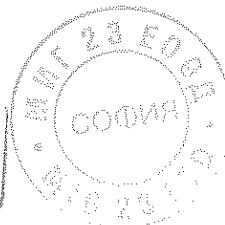

Printed by cci 14/11/2013



REPORT OF PERFORMANCE

249-09

APPARATUS The busbar and switch compartment of a three-phase SF₆-insulated metal-enclosed switchgear assembly, incorporating a switch-fuse combination

TYPE CGMCosmos P **SERIAL No.** 31756402

24 kV – 630 A – 20 ⁽¹⁾ kA – 50/60 Hz

⁽¹⁾ See note on page 4.

CLIENT Ormazabal Distribución Secundaria, Igorre (Vizcaya), Spain

MANUFACTURER Ormazabal Distribución Secundaria, Igorre (Vizcaya), Spain

TESTED BY KEMA HIGH-POWER LABORATORY
Utrechtseweg 310 - 6812 AR Arnhem - The Netherlands

DATE(S) OF TESTS 12 March 2009

TEST SPECIFICATION The tests have been carried out in accordance with the client's instructions. Test procedure and test parameters were based on IEC 62271-200, Annex A.

This report applies only to the apparatus tested. The responsibility for conformity of any apparatus having the same designations with that tested rests with the Manufacturer.

This report consists of 25 sheets in total.

This report falls under the scope of the accreditation certificate L 020 of the Dutch Council for Accreditation. See information sheet (page 2).

© Copyright: Only integral reproduction of this report is permitted without written permission from KEMA. Electronic copies in e.g. PDF-format or scanned version of this report may be available and have the status "for information only". The sealed and bound version of the report is the only valid version.

KEMA Nederland B.V.

на основание чл. 2 от ЗЗЛД

Managing Director

Arnhem, 25 June 2009

Printed by: i:\011\w\velatia\eds 14/09/2015

ВЯРНО С
ОРИГИНАЛА

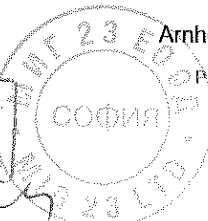

Handwritten signature



249-09

IDENTIFICATION OF THE APPARATUS TESTED

Page 4

RATINGS ASSIGNED BY THE MANUFACTURER

Voltage		24 kV
Number of poles		3
Frequency		50/60 Hz
Normal current:		
Busbar		630 A
Feeder circuit		630 A
Short-time withstand current:		Peak withstand current:
Main circuit	20/21 kA for 1 s	55 kA
Earthing circuit	20/21 kA for 1 s	55 kA
Internal arc current	20/21 ⁽¹⁾ kA for 1 s	55 kA
Pressure for insulation SF ₆ at 20 °C		0,13 MPa
Classification IAC		AFL

⁽¹⁾ IEC rating / Rating assigned by the manufacturer.
On request of the client the test in this report has been based on a short-circuit current of 21 kA.

DESCRIPTION OF APPARATUS TESTED

The busbar and switch compartment of a three-phase SF₆-insulated metal-enclosed switchgear assembly, incorporating a switch-fuse combination.

Minimum pressure for interruption at 20 °C	0,115 MPa
Maximum pressure for interruption at 20 °C	0,13 MPa

LIST OF DRAWINGS

*On request of the manufacturer the following drawings are included in this report.
KEMA has not verified these drawings.*
DOC-2685 Rev. 02
DOC-2869 Rev. 01
DOC-2870 Rev. 01
DOC-2871 Rev. 01
DOC-2872 Rev. 01
DOC-2873 Rev. 01
DOC-2930 Rev. 01





249-09

SUMMARY: Checking of the prospective current

Page 7

Test no.			090312 4002				
	L1	kA	-43,6				
Peak value of current	L2	kA	-42,8				
	L3	kA	56,8				
	L1	kA	19,7				
Symmetrical current, beginning	L2	kA	20,1				
	L3	kA	19,9				
	L1	kA	19,7				
Symmetrical current, middle	L2	kA	20,1				
	L3	kA	19,9				
	L1	kA	19,9				
Symmetrical current, end	L2	kA	20,3				
	L3	kA	20,1				
	L1	kA	19,8				
Symmetrical current, average	L2	kA	20,2				
	L3	kA	20,0				
Average current, three phase		kA	20,0				
Current duration		s	1,11				
Thermal equivalent			21,0 kA during 1,06 s				
Gas pressure at 20 °C		MPa	-				

Handwritten mark resembling a stylized 'B' or 'G' with an arrow pointing downwards.

REMARKS	
090312-4002	No visible disturbance.

Version: 1



Printed by :0#.w\velatia\eds 14/09/2015

Handwritten mark resembling a stylized 'B' or '10'.

REPORT OF PERFORMANCE

529-03

APPARATUS A three-phase SF₆-insulated ring main unit.

TYPE CGMcosmos-2L **SERIAL No.** K12520001

24 kV – 630 A – 20 kA – 50 Hz

CLIENT Ormazabal y Cia S.A.,
Igorre (Vizcaya), Spain

MANUFACTURER Ormazabal y Cia S.A.,
Igorre (Vizcaya), Spain

TESTED BY KEMA HIGH-POWER LABORATORY
Utrechtseweg 310 - 6812 AR Arnhem - The Netherlands

DATE(S) OF TESTS 17th December 2003

TEST SPECIFICATION The tests have been carried out in accordance with the client's instructions.
Test procedure and test parameters were based on IEC 62271-200, Annex A

Handwritten checkmark and signature.

This report consists of 23 sheets in total.

This report falls under the scope of the accreditation certificate L 020 of the Dutch Council for Accreditation.
See information sheet (page 1).

© Copyright: Only integral reproduction of this report, or reproductions of this page accompanied by any page(s) on which are stated the endorsed ratings of the apparatus tested, are permitted without written permission from KEMA. Electronic copies in e.g. PDF-format or scanned version of this report may be available and have the status "for information only".
The sealed and bound version of the report is the only valid version.

KEMA Nederland B.V.
на основание чл. 2 от ЗЗЛД

P.G.A. Bus
Manager High-Power Laboratory

Arnhem, 10th March 2004

Printed by cci 14/11/2013

ВЯРНО С
ОРИГИНАЛА

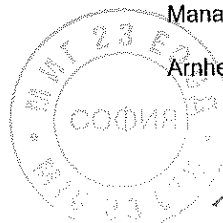

Handwritten signature.

C2

F2-8-1

Handwritten signature.

20

1 Certificate

A Certificate contains a record of a series of type tests carried out strictly in accordance with a recognized standard. The equipment tested has fulfilled the requirements of this standard and the relevant ratings assigned by the manufacturer are endorsed by KEMA. The Certificate is applicable only to the equipment tested. KEMA is responsible for the validity and the contents of the Certificate.

The responsibility for conformity of any apparatus having the same designation as the one tested rests with the manufacturer. The Certificate contains the essential drawings and a description of the equipment tested.

Detailed rules are given in KEMA's Certification procedure.

2 Report of Performance

A Report of Performance contains a record of one or more tests which have been carried out according to the client's instructions. These tests are not necessarily in accordance with a recognized standard. The test results do not verify ratings of the test object.

KEMA issues three types of Reports of Performance:

2.1 The tests have been carried out strictly in accordance with The apparatus has complied with the relevant requirements.

This sentence will appear on the front page of a Report of Performance if the tests have been performed in accordance with a recognized standard, but the series of tests does not completely fulfil the requirements for a Certificate of Compliance (for example, if the number of test duties is not a complete series of type tests). The Report contains verified drawings and a description of the equipment tested. Detailed rules are given in KEMA's Certification procedure. The condition of the test object after the tests is assessed and recorded in the Report.

2.2 The tests have been carried out in accordance with the client's instructions. Test procedure and test parameters were based on

This sentence will appear on the front page of a Report of Performance if the number of tests, the test procedure and the test parameters are based on a recognized standard and related to the ratings assigned by the manufacturer. If the apparatus does not pass the tests such behaviour will be mentioned on the front sheet. Verification of the drawings (if submitted) and assessment of the condition after the tests is only done on the client's request.

2.3 The tests have been carried out according to the client's instructions.

This sentence will appear on the front page of a Report of Performance if the tests, test procedure and/or test parameters are not in accordance with a recognized standard.

3 Standards

When reference is made to a standard, and the date of issue is not stated, this applies to the latest issue, including amendments which have been officially published prior to the date of the tests.

4 Official and uncontrolled test documents

The official test documents of KEMA High-Power Laboratory are issued in bound form. Uncontrolled copies may be provided as loose sheets or as a digital file for convenience of reproduction by the client. The copyright has to be respected at all times.

5 Accuracy of measurement

In the table of test results the measured quantities are given in three digits. This method of presentation does not indicate an accuracy. The guaranteed uncertainty in the figures mentioned, taking into account the total measuring system, is less than 5%, unless mentioned otherwise.

6 Qualified by RvA (Dutch Council for Accreditation)

KEMA High-Power Laboratory and High-Voltage Laboratory have been entered in the RvA-register for laboratories under resp. Nrs. L 020 and L 218 for the testing services as defined in the Field of Accreditation.

The accreditation is carried out in accordance with ISO/IEC 17025.



Handwritten signature

Handwritten signature



Handwritten signature



TABLE OF CONTENTS:

INFORMATION SHEET 1

IDENTIFICATION OF THE APPARATUS TESTED 3

 Ratings assigned by the manufacturer 3

 Description of apparatus tested 3

GENERAL INFORMATION 4

 The tests were witnessed by 4

 The tests were observed by 4

 Notes 4

LEGEND 5

DUTY: Checking of the prospective current 6

 Test circuit 7

 Test 031217-4007 8

CONDITION / INSPECTION AFTER TEST 9

DUTY: Internal fault test 10

 Test circuit 11

 Test arrangement 12

 Photographs before test 13

 Test 031217-4008 16

CONDITION / INSPECTION AFTER TEST 17

 Photograph after test 18

DRAWINGS 19 to 22



Handwritten signature

ВЯРНО С
ОРИГИНАЛА

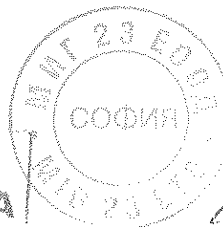

Handwritten signature

b

RATINGS ASSIGNED BY THE MANUFACTURER

Voltage		24 kV
Number of poles		3
Frequency		50 Hz
Normal current:		
Main busbar		630 A
Feeder circuit		630 A
Short-time withstand current:		Peak withstand current:
Main circuit	20 kA for 1 s	50 kA
Earthing circuit	20 kA for 1 s	50 kA
Classification IAC		AF
Internal arc	20 kA for 1 s (1)	50 kA peak
(1) Tests carried out at 21 kA – 1 s		

Handwritten checkmark and signature.

DESCRIPTION OF APPARATUS TESTED

A three-phase SF₆-insulated ring main unit.

DRAWINGS

According to the client the following drawing number(s) refer.
KEMA has not verified these drawings.

- DOC-2149 Rev. 1
- DOC-2145 Rev. 1
- DOC-2146 Rev. 1
- DOC-1449 Rev. 1

Handwritten signature.

ВЯРНО С
ОРИГИНАЛА

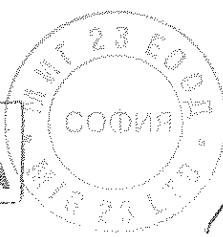

Handwritten signature.



THE TESTS WERE WITNESSED BY

Name	Company
Mena, M. Rodriguez, J. Sebastian, M.	Ormazabal y Cia S.A., Igorre (Vizcaya), Spain

THE TESTS WERE OBSERVED BY

Name	Company
Jorna, R.E.	KEMA, Arnhem, The Netherlands



NOTES

- The tests were recorded on regular-speed video and on high-speed video.



TEST REPORT

31009211-3GB

PERFORMED TEST Internal arc test, 21 KA-1s AFL

OBJECT TESTED The cable compartment of a three-phase metal-enclosed SF6-Insulated switchgear assembly.

TYPE	SERIAL No.
CGMCosmos-L	31009211-M5

STANDARD IEC 62271-200:2003

MANUFACTURER ORMAZABAL

DATE OF TEST 1st of October 2010

TEST SPECIFICATION The test object was submitted to the requested tests, according to the procedures specified in the above mentioned Standard and the client's Instructions.

The present report refers only and exclusively to the samples tested and at the moment and conditions in which the measures were made.
The full or partial reproduction of this document is categorically forbidden without the written approval of ORMAZABAL.

Pages 11
Annexes 1

VERIFIED BY APPROVED BY

на основание чл. 2 от ЗЗЛД



Elias Echevarría Inaki Ordo
Laboratory Manager

Amorebieta-Etxano, 17th of January 2011

ВЯРНО С
ОРИГИНАЛА

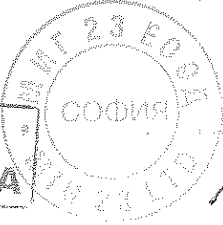

IDENTIFICATION OF THE TEST OBJECT

31009211-3GB

RATED CHARACTERISTICS

Manufacturer	ORMAZABAL
Designation	CGMCosmos
Type	CGMCosmos L
Serial number	31009211-M5
Rated voltage	24 kV
Rated current	630 A
Frequency	50/60 Hz
Rated short-time withstand current	21 kA
Rated peak withstand current	54.6 kA
Rated duration of short-circuit	1 s
Rated SF6 pressure	1.3 bar
iAC Classification	AFL

DESCRIPTION

The cable compartment of a three-phase metal-enclosed SF6-insulated switchgear assembly.

ORMAZABAL, S.A. - C/Industria, 10 - 48940 Leizor (Bizkaia) - Spain - Tel: +34 94 511 21 00 - Fax: +34 94 511 21 01 - Email: ormazabal@ormazabal.com

14/09/2015

ORMAZABAL Corporate Technology S.A.

ORMAZABAL, Corporate Technology, Parque Empresarial Boros Parcela 24, 48940 Amorebieta-Etxano (Bizkaia) Spain

**ВЯРНО С
ОРИГИНАЛА**

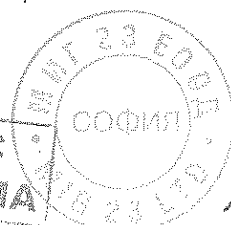

Printed by I:\08.wjvelatia\eds 14/09/2015



SUMMARY OF TESTS

31009211-3GB

PERFORMED TEST

The test object was submitted to an internal arc test with an expected current value of 21 kA and an expected peak current value of 54.6 kA during 1 second.

The indicators used in the test were A accessibility class as indicated in clause A3.3 of annex A IEC 62271-200:2003.

RESULTS TABLE

Register number		T31009211_14
Peak value of current, 2 phase	kA	44.37
Symmetrical current, 2 phase, average	kA	18.34
Duration	s	1.003



CONCLUSIONS

The acceptance criteria from IEC 62271-200:2003 Annex A clause. A.6 are applied:

-A accessibility:

Criterion No. 1: Correctly secured doors and covers do not open. PASSED

Criterion No. 2: No material fragmentation of the enclosure occurs within the time specified for the test. Projections of small parts, up to an individual mass of 60g, are accepted. PASSED

Criterion No. 3: Arcing does not cause holes in the accessible sides up to a height of 2m. PASSED

Criterion No. 4: Indicators do not ignite due to the effect of hot gases. PASSED

Criterion No. 5: The enclosure remains connected to its earthing point. PASSED

The test was PASSED.

Version: 04/2013 - Internal Release - subject of the approval process. This document contains confidential information.

Handwritten signature

**ВАРНО С
ОРИГИНАЛА**

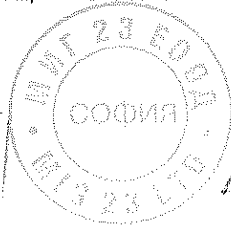

TEST REPORT

31009211-4GB

PERFORMED TEST Internal arc test, 21 kA-1s AFL

OBJECT TESTED The busbar and three-phase three-position switch-fuse combination compartment of an SF6-insulated metal-enclosed switchgear assembly.

TYPE CGMCosmos-L **SERIAL No.** 31009211-M6

STANDARD IEC 62271-200:2003

MANUFACTURER ORMAZABAL

DATE OF TEST 1st of October 2010

TEST SPECIFICATION The test object was submitted to the requested tests, according to the procedures specified in the above mentioned Standard and the client's instructions.

The present report refers only and exclusively to the samples tested and at the moment and conditions in which the measures were made. The full or partial reproduction of this document is categorically forbidden without the written approval of ORMAZABAL.

Pages 11
Annexes 1



VERIFIED BY APPROVED BY

НА ОСНОВАНИЕ ЧЛ. 2 ОТ ЗЗЛД

ENAC ENSAYES S 6973 E 1521 Laboratory Chief ENAC ENSAYES S 6973 E 1521 Laboratory Manager

Amorebieta-Etxano, 17th of January 2011

ВЯРНО С
ОРИГИНАЛА



IDENTIFICATION OF THE TEST OBJECT

31009211-4GB

RATED CHARACTERISTICS

Manufacturer	ORMAZABAL
Designation	CGMCosmos
Type	CGMCosmos L
Serial number	31009211-M6
Rated voltage	24 kV
Rated current	630 A
Frequency	50/60 Hz
Rated short-time withstand current	21 kA
Rated peak withstand current	54.6 kA
Rated duration of short-circuit	1 s
Rated SF6 pressure	1.3 bar
IAC Classification	AFL

DESCRIPTION

The busbar and three-phase three-position switch-fuse combination compartment of an SF6-insulated metal-enclosed switchgear assembly.

The busbar and three-phase three-position switch-fuse combination compartment of an SF6-insulated metal-enclosed switchgear assembly.

Version: 1

ORMAZABAL Corporate Technology, Parque Empresarial Borda Parcela 24, 48340 Amorebieta-Etxano (Bizcaya) Spain.

ORMAZABAL
Corporate Technology
LABORATORY

ВЯРНО С
ОРИГИНАЛА

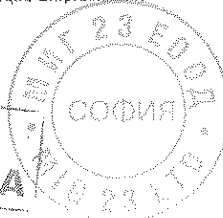

Printed by i:0#.w|velatia\eds 14/09/2015

SUMMARY OF TESTS

31009211-4GB

PERFORMED TEST

The test object was submitted to an internal arc test with an expected current value of 21 kA and an expected peak current value of 54.6 kA during 1 second.

The indicators used in the test were A accessibility class as indicated in clause A3.3 of annex A IEC 62271-200:2003.

RESULTS TABLE

Register number			T31009211_15
	R	kA	45.38
Peak value of current	S	kA	42.74
	T	kA	55.80
	R	kA	21.90
Symmetrical current, phase average	S	kA	21.91
	T	kA	21.64
Duration		s	0.965

CONCLUSIONS

The acceptance criterions from IEC 62271-200:2003 Annex A clause. A.6 are applied:

-A accessibility:

Criterion No. 1: Correctly secured doors and covers do not open. PASSED

Criterion No. 2: No material fragmentation of the enclosure occurs within the time specified for the test. Projections of small parts, up to an individual mass of 60g, are accepted. PASSED

Criterion No. 3: Arcing does not cause holes in the accessible sides up to a height of 2m. PASSED

Criterion No. 4: Indicators do not ignite due to the effect of hot gases. PASSED

Criterion No. 5: The enclosure remains connected to its earthing point. PASSED

The test was PASSED.

INFORMACIÓN PROPRIETARIA DE ORMAZABAL. Reservados todos los derechos. No se permite la explotación económica ni la transformación de esta obra. Queda permitida la impresión en su totalidad.



500803

ORMAZABAL Corporate Technology, Parque Empresarial Boreas Parcela 24, 48340 Amorebieta-Etxano (Bizkaia) Spain

ORMAZABAL
Corporate Technology
LABORATORIO

**ВЯРНО С
ОРИГИНАЛА**

ММТ 23 ЕО
СОФИЯ
ММТ 23 LTD

Printed by f08.wjvelatia\eds 14/09/2015

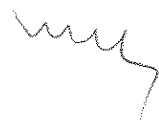

This Document is an English translation, performed by ORMAZABAL, of the original Technical Annex of Accreditation



Rev.5, dated 08/09/14.

<https://www.enac.es/documents/7020/b5adee99-debf-4f8c-b788-6f21f82a1132>

(UNE-EN Standards, are the official versions of the corresponding edition of EN Standards)

SCOPE OF ACCREDITATION

ORMAZABAL CORPORATE TECHNOLOGY A.I.E.

Address: Parque Empresarial Boroa, Parcela 3A; 48340 Amorebieta-Etxano (Bizkaia) SPAIN

Is accredited by the **ENTIDAD NACIONAL DE ACREDITACIÓN**, according the criteria collected in EN ISO/IEC 17025:2005 (CGA-ENAC-LEC), for performing the following tests on:

Electrical Distribution Equipment

Category 0 (Tests in the permanent laboratory)

PRODUCT / TEST OBJECT	TEST	STANDARD / PROCEDURE
High-voltage/low voltage prefabricated substation	Dielectric tests: <ul style="list-style-type: none"> ▪ Power Frequency: up to 100 kV ▪ Lightning Impulse: up to 288 kV 	IEC 62271-202:2006 IEC 62271-202:2014. UNE-EN 62271-202:2007.
	Temperature-rise tests	
	Short-time and peak withstand current tests on main and earthing circuits: up to 80kA/3s	
	Internal arcing test: up to 40kA/1s	
	Degrees of Protection IP: from 2X up to 4X from X3 up to X6	IEC 60529 :2001 IEC 60529 :2003 CORR. IEC 60529 :2007 CORR.
	Degrees of Protection IK: from 06 up to 10	IEC 62262 :2002

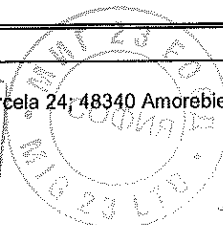
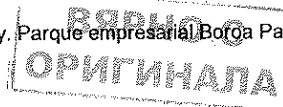



Alternating current disconnectors and earthing switches	<p>Dielectric tests:</p> <ul style="list-style-type: none"> ▪ Power Frequency: up to 100 kV ▪ Lightning Impulse: up to 288 kV ▪ Partial discharge measurement: up to 100 kV and up to 2pC <p>Temperature-rise tests</p> <p>Measurement of the resistance of circuits</p> <p>Operating and mechanical endurance tests</p> <p>Short-time and peak withstand current tests on main and earthing circuits: up to 80kA</p> <p>Test to prove the short-circuit making performance of earthing switches: up to 40kA</p>	<p>IEC 62271-102:2001 IEC 62271-102: 2002 CORRIGENDUM 1 IEC 62271-102: 2003 CORRIGENDUM 2 IEC 62271-102: 2005 CORRIGENDUM 3 IEC 62271-102/A1: 2011 IEC 62271-102/A1: 2012 CORRIGENDUM 1 IEC 62271-102/A1&A2:2013</p> <p>UNE-EN 62271-102:2005 UNE-EN 62271-102:2005 ERRATUM 2011 UNE-EN 62271-102/A1:2012</p>
	<p>Degrees of Protection IP: from 2X up to 4X from X3 up to X6</p>	<p>IEC 60529 :2001 IEC 60529 :2003 CORR. IEC 60529 :2007 CORR.</p>
	<p>Degrees of Protection IK: from 06 up to 10</p>	<p>IEC 62262 :2002</p>
High-voltage switches for rated voltages above 1 kV and less than 52 kV	<p>Dielectric tests:</p> <ul style="list-style-type: none"> ▪ Power Frequency: up to 100 kV ▪ Lightning Impulse: up to 288 kV ▪ Partial discharge measurement: up to 100 kV and up to 2pC <p>Temperature-rise tests</p> <p>Measurement of the resistance of circuits</p> <p>Mechanical operating tests</p> <p>Short-time and peak withstand current tests on main and earthing circuits: up to 80kA</p> <p>Making and breaking tests: up to 2500MVA, 36kV</p>	<p>IEC 60265-1:1998 IEC 60265-1:2000 CORRIGENDUM IEC 62271-103:2011 IEC 62271-103 CORRIGENDUM 1: 2013.</p> <p>UNE 60265-1:1999. UNE 60265-1:2005 CORRIGENDUM UNE-EN 62271-103 :2012</p>
	<p>Degrees of Protection IP: from 2X up to 4X from X3 up to X6</p>	<p>IEC 60529 :2001 IEC 60529 :2003 CORR. IEC 60529 :2007 CORR.</p>
	<p>Degrees of Protection IK: from 06 up to 10</p>	<p>IEC 62262 :2002</p>

ВЕРНО С
ОРИГИНАЛА

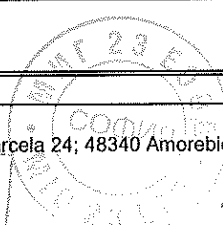

High-voltage Alternating current circuit-breakers	<p>Dielectric tests:</p> <ul style="list-style-type: none"> ▪ Power Frequency: up to 100 kV ▪ Lightning Impulse: up to 288 kV ▪ Partial discharge measurement: up to 100 kV and up to 2pC <p>Temperature-rise tests</p> <p>Measurement of the resistance of circuits</p> <p>Mechanical operating tests</p> <p>Short-time and peak withstand current tests: up to 80kA</p> <p>Making and breaking tests: up to 2500MVA, 36kV</p>	<p>IEC 62271-100:2008 IEC 62271-100/A1:2012 IEC62271-100/A1 CORRIGENDUM 1 :2012</p> <p>UNE-EN 62271-100:2003. UNE-EN 62271-100/A1:2004 UNE-EN 62271-100:2004 ERRATUM UNE-EN 62271-100/A2:2007 UNE-EN 62271-100:2011 UNE-EN 62271-100:2011/ Versión Corregida Abril 2014</p>
	Degrees of Protection IP: from 2X up to 4X from X3 up to X6	<p>IEC 60529 :2001 IEC 60529 :2003 CORR. IEC 60529 :2007 CORR.</p>
	Degrees of Protection IK: from 06 up to 10	<p>IEC 62262 :2002</p>
A.C. metal-enclosed switchgear and controlgear for rated voltages above 1 kV and up to and including 52 kV	<p>Dielectric tests:</p> <ul style="list-style-type: none"> ▪ Power Frequency: up to 100 kV ▪ Lightning Impulse: up to 288 kV ▪ Partial discharge measurement: up to 100 kV and up to 2pC <p>Temperature-rise tests</p> <p>Measurement of the resistance of circuits</p> <p>Mechanical operating tests</p> <p>Short-time and peak withstand current tests: up to 80kA</p> <p>Internal fault test: up to 40kA/1s</p>	<p>IEC 62271-200: 2003 IEC 62271-200: 2011.</p> <p>UNE-EN 62271-200:2005 UNE-EN 62271-200:2012.</p>
	Degrees of Protection IP: from 2X up to 4X from X3 up to X6	<p>IEC 60529 :2001 IEC 60529 :2003 CORR. IEC 60529 :2007 CORR.</p>
	Degrees of Protection IK: from 06 up to 10	<p>IEC 62262 :2002</p>

ВЕРНО С
ОРИГИНАЛА

High-voltage switchgear and controlgear	Dielectric tests: <ul style="list-style-type: none"> ▪ Power Frequency: up to 100 kV ▪ Lightning Impulse: up to 288 kV ▪ Partial discharge measurement: up to 100 kV and up to 2pC 	IEC 62271-1:2007 IEC 62271-1/A1:2011
	Temperature-rise tests	UNE-EN 62271-1:2009 UNE-EN 62271-1/A1:2011.
	Measurement of the resistance of circuits	UNE-EN 60694:1998. UNE-EN 60694:1999
	Mechanical operating tests	CORRIGENDUM UNE-EN 60694/A1:2002 UNE-EN 60694/A2:2002
	Short-time and peak withstand current tests: up to 80kA	
	Degrees of Protection IP: from 2X up to 4X from X3 up to X6	IEC 60529 :2001 IEC 60529 :2003 CORR. IEC 60529 :2007 CORR.
	Degrees of Protection IK: from 06 up to 10	IEC 62262 :2002
Power transformers	Routine tests	IEC 60076-1:1993. IEC 60076-1/A1:1999 IEC 60076-1:1997 CORRIGENDUM 1 IEC 60076-1:2011 UNE-EN 60076-1:1998. UNE-EN 60076-1/A1:2001 UNE-EN 60076-1/A12:2002 UNE-EN 60076-1:2013
	Temperature-rise tests	IEC 60076-2:1998. IEC 60076-2:1 IEC 60076-3:2013998 ERRATUM 2006 IEC 60076-2:2011 UNE-EN 60076-2:2013.
	Dielectric tests: <ul style="list-style-type: none"> ▪ Separate source AC: up to 100kV ▪ Induced AC ▪ Lightning Impulse: up to 288kV 	IEC 60076-3:2000. IEC 60076-3:2000 CORRIGENDUM 1 IEC 60076-3:2013 UNE-EN 60076-3:2002. UNE-EN 60076-3:2006 ERRATUM
	Ability to withstand short circuit	IEC 60076-5:2006 UNE-EN 60076-5:2002 UNE-EN 60076-5:2008

ВЯРНО С
ОРИГИНАЛА

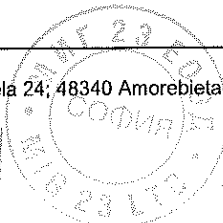

	Degrees of Protection IP: from 2X up to 4X from X3 up to X6	IEC 60529 :2001 IEC 60529 :2003 CORR. IEC 60529 :2007 CORR.
	Degrees of Protection IK: from 06 up to 10	IEC 62262 :2002
Requirements for Subsurface, vault and Pad-Mounted Load-Interrupter switch-gear and fused load-interrupter switch-gear for alternating current systems up to 38 kV	Dielectric tests: <ul style="list-style-type: none"> Power Frequency: up to 100 kV Lightning Impulse: up to 288 kV Partial discharge measurement: up to 100 kV and up to 2pC Temperature-rise tests Measurement of the resistance of circuits Mechanical operating tests Short-time and peak withstand current tests on main and earthing circuits: up to 80kA Making and breaking tests: up to 2500MVA, 38kV	IEEE C37.74:2003.
Automatic circuit reclosers and fault interrupters for alternating current Systems up to 38 kV	Dielectric tests: <ul style="list-style-type: none"> Power Frequency: up to 100 kV Lightning Impulse: up to 288 kV Partial discharge measurement: up to 100 kV and up to 2pC Temperature-rise tests Measurement of the resistance of circuits Mechanical operating tests Short-time and peak withstand current tests on main and earthing circuits: up to 80kA Making and breaking tests: up to 2500MVA, 38kV: <ul style="list-style-type: none"> Line charging current and cable charging current interruption tests Making current capability Rated symmetrical interrupting current tests Degrees of Protection	IEEE C37.60:2012 IEC 62271-111:2012

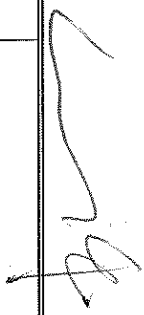

ВЯРНО С
ОРИГИНАЛА

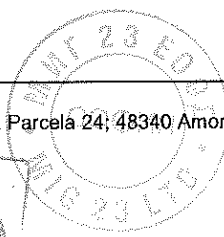
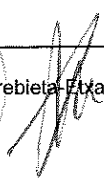

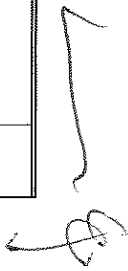

<p>Metal-Enclosed Interrupter Switchgear (1kV – 38kV)</p>	<p>Dielectric tests:</p> <ul style="list-style-type: none"> ▪ Power Frequency: up to 100 kV ▪ Lightning Impulse: up to 288 kV ▪ Partial discharge measurement: up to 100 kV and up to 2pC <p>Temperature-rise tests Measurement of the resistance of circuits Mechanical operating tests Short-time and peak withstand current tests on main and earthing circuits: up to 80kA Making and breaking tests: up to 2500MVA, 38kV:</p> <ul style="list-style-type: none"> ▪ Line charging current and cable charging current interruption tests ▪ Making current capability ▪ Rated symmetrical interrupting current tests <p>Degrees of Protection</p>	<p>IEEE C37.20.3:2013 IEEE C37.100.1:2007</p>
<p>Electric and Electronic Equipment</p>	<p>Degrees of Protection IP: from 2X up to 4X from X3 up to X6</p> <p>Degrees of Protection IK: from 06 up to 10</p>	<p>IEC 60529:2001 IEC 60529:2001 CORRIGENDUM 1:2003 IEC 60529:2001 CORRIGENDUM 2:2007</p> <p>IEC 62262:2002</p>

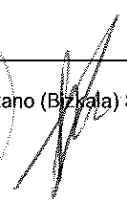
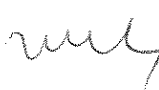

ВЯРНО С
ОРИГИНАЛА

23 EOD
MIG 23 LTD

3

ДЕКЛАРАЦИЯ

Долуподписаната **НАТАША КОСТАДИНОВА НЕШЕВА**
на основание чл. 2 от ЗЗЛД

на основание чл. 2 от ЗЗЛД

дре
УЪР" АД,

Декларирам, че:

Предвидените за доставка от нас КРУ СрН подлежат на рециклиране в завода-производител ORMAZABAL – Испания след изтичане на експлоатационния живот на съоръженията.

гр. София

05.01.2018 г.

на основание чл. 2 от ЗЗЛД

Наташа Нешева

/Изпълнителен директор/

ВЯРНО С
ОРИГИНАЛА



Handwritten signature

Handwritten signature

Handwritten signature

4.8. ПРОВЕРКА ЗА НАЛИЧИЕТО НА НАПРЕЖЕНИЕ И СЪГЛАСУВАНЕТО НА ФАЗИТЕ

За да се потвърди правилното свързване на кабелите за СН към шкафите с изводи в трансформаторната подстанция, трябва да се използва уредът за сравняване на фазите ekorSPC^[17] от Ormazabal.

Най-напред свържете червените кабели на модула ekorSPC към точките за изпитване на същата фаза на съответните модули ekorVPIS^[18], а черния кабел – към точката за изпитване на заземяването. Това действие трябва да се повтори за всички фази L1, L2 и L3.

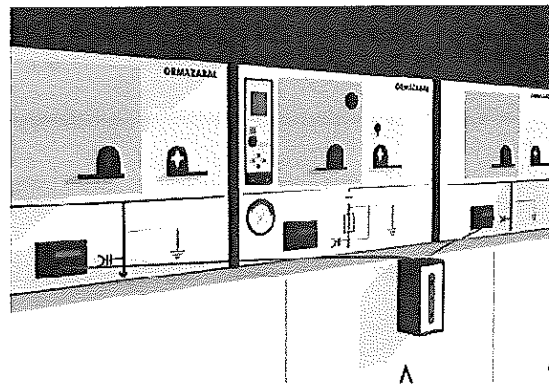
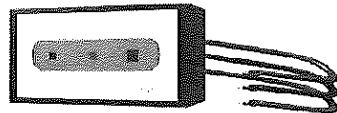

Фигура 4.46: ekorSPC

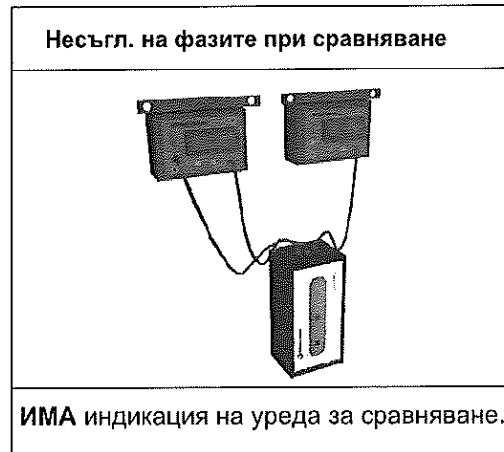

^[17] Опционално могат да се използват и други уреди за сравняване на фази, съвместими с IFC 61958.

^[18] Вж. раздел 1.1.1. ekorVPIS – Модул за индикация на наличие на напрежение.

MIG 23 Ltd

www.mig23-bg.com
mv@mig23-bg.com

ДЕКЛАРАЦИЯ ЗА СЪОТВЕТСТВИЕ

Долуподписаният Антон Иванов Илиев,
МВР

на основание чл. 2 от ЗЗЛД

на основание чл. 2 от ЗЗЛД

ДЕКЛАРИРАМ:

Предлаганите от фирма „МИГ 23“ ЕООД - Компактни КРУ в метален шкаф 12/24(25) kV, 630 A, 16 кА, с SF6 изолация, с товари прекъсвачи, производство на Ormazabal – Испания, съответстват на изискванията на стандартите, посочени в параграф „Съответствие на предложеното изпълнение със стандартизационните документи“ на настоящата тръжна процедура:
„Доставка и монтаж на бетонови комплектни трансформаторни постове (БКТП)“ с реф. № PPD 18-063

Известно ми е, че при деклариране на неверни данни, нося наказателна отговорност по чл. 313 от НК.

06.08.2018 г.

Декларатор

на основание чл. 2 от ЗЗЛД

(Антон Илиев)



ВИРЛАБ, С.А. Подразделение на УРБАР ИНЖЕНИЕРОС, С.А.	ДОКЛАД НОМЕР 111640	СТРАНИЦА НОМЕР 1/279
--	--------------------------------------	---------------------------------------

**ДОКЛАД ОТ ИЗПИТВАНЕТО ЗА ОЦЕНКА НА
СЕИЗМИЧНАТА УСТОЙЧИВОСТ НА
„СИСТЕМАТА CGM COSMOS L+P+V“
НА ОРМАСАБАЛ, С.А.**

ЗАБЕЛЕЖКА: Съгласно разпоредбите на точка 5.10.2 от Стандарта ISO-IEC 17025:2005 следва да се направи следното предупреждение:

- Резултатите от настоящия доклад се отнасят единствено и изключително за подложките на изпитване образци.
- Забранява се частичното или цялостно възпроизвеждане на този документ без писменото разрешение от страна на лабораторията.

Дата	Извършил:	Проверил:	ВИРЛАБ, С.А. Подразделение на УРБАР ИНЖЕНИЕРОС, С.А.
	<i>нечетлив подпис</i>	<i>нечетлив подпис</i>	Индустриална зона Астеасу Зона Б, Сграда 44 20159 Астеасу (Гипускоа) ИСПАНИЯ
27.09.11	Хуан Антонио ПЕРЕС	Алберто КОРАЛ	www.virlab.es Email: virlab@urbar.com Тел.: +34 943 69 15 00 Факс: +34 943 69 26 67

Кръгъл печат на ВИРЛАБ, ЛАБОРАТОРИЯ ЗА ВИБРАЦИОННИ ИЗПИТВАНИЯ



12.0.- ЗАКЛЮЧЕНИЯ

Разпределителната уредба „СИСТЕМА CGM COSMOS L+P+V“ на ОРМАСАБАЛ, С.А., съставена от три (3) *Килии*, съгласно чертеж номер DOC-3410, Преразглеждане 01 от дата 08.04.11 год., с характеристики, описани в точка 3.0, която е предназначена за **ПОДСТАНЦИИ И ТРАФОПОСТОВЕ**, е подложена на сеизмични изпитвания, както е посочено в обяснената в точка 8.0 процедура, в съответствие с европейския стандарт **UNE EN 60068-3-3 от 1994 год.**, стандарта **NSR-98** (Колумбия), спецификациите **ETGI-1020** (Чили), **ESE-010** (Enersis) и **NSP-420** (Венецуела), както и въз основа на американските стандарти **IEEE-344** от 2004 год. и **IEEE-693** от 2005 год.

В точка 11.0 са описани резултатите от изпитванията, извършени по отношение на разпределителната уредба. Съоръжението е издържало удовлетворително изпитванията, без по него да са открити аномалии или структурни повреди.

Единственото отклонение, отчетено по време на изпитванията, се наблюдава при изпитване № 21, многочестотно сеизмично изпитване от ниво **S2**, извършено по посока **YZ**, *странично* спрямо разпределителната уредба и едновременно с това *вертикално*, в резултат на което са получени микродеформации със стойност по-висока от 1000 (1198), тоест по-висока от максимално допустимата стойност, по една от четирите ленти (G4), поставени в основата на съоръжението.

С цел намаляване на напрежението в съоръжението е увеличен броят на болтовете от 12 на 18 (с по два (2) на клетка), с което максималният брой микродеформации при изпитване № 22 спада от 1198 на 719 при прилагане на същото ниво като при изпитване № 21.

В **ПРИЛОЖЕНИЕ I** са представени в графична форма данните от сензорите за измерване на механични деформации, отчетени в резултат на многочестотните и синусоидалните сеизмични изпитвания, по време на които са прилагани резонансните честоти на уредбата. Резултатите от тези изпитвания, с изключение на горесцитирания случай, не надвишават 80% от максималната граница на провлачване на материала, дефинирана посредством 1000 микродеформации.

В **ПРИЛОЖЕНИЕ II** са отразени честотните спектри, интегрирани по максимални стойности, на акселерометрите от Група 1, закрепени върху вибрираща платформа, като е посочено нивото, приложено по време на скрининга преди и след сеизмичните изпитвания.

В същото това **ПРИЛОЖЕНИЕ** е отразен честотният спектър не само на Група 1 акселерометри, закрепени върху вибрираща платформа; но и на Група 2, която е поставена в Центъра на тежест на съоръжението. Посочено е и нивото, приложено при синусоидалните сеизмични изпитвания, осъществени по посока **Y** (*странично*) и **X** (*отпред-назад*) спрямо разпределителната уредба.

В **ПРИЛОЖЕНИЕ III** са представени предавателните функции (*модул и фаза*), получени при първоначалния и крайния скрининг при ниво на ускорение 0,1 g, като въз основа на тези функции се прави извод, че най-значимите резонансни честоти на *Килиите* са в диапазона от 0.5 до 35 Hz.

Кръгъл печат на ВИРЛАБ, ЛАБОРАТОРИЯ ЗА ВИБРАЦИОННИ ИЗПИТВАНИЯ

ВЯРНО С
ОРИГИНАЛА

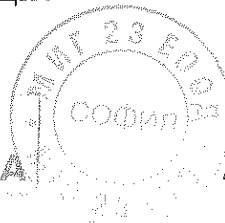

В приложената по-долу таблица са показани резонансите на точка 2, получени при началния и крайния скрининг.

ТОЧКА НОМЕР	РЕЗОНАНС (Hz)			
	Хоризонтална посока „X“ (отпред - назад)		Хоризонтална посока „Y“ (странично)	
	Начален скрининг	Краен скрининг	Начален скрининг	Краен скрининг
2 (ЦЕНТЪР НА ТЕЖЕСТТА)	12,87	10,49	6,68	7,63

От анализа на тези резултати се стига до извода, че отклоненията между крайните и началните резонанси са в порядъка на 14,2% в посока Y и в порядъка на 18,5% в посока X, при всички случаи под 20-те %, които представляват допустимата стойност на отклонение съгласно стандарт IEC 693/2005.

Независимо от това следва да се отбележи, че посочените отклонения реално са по-ниски, ако се вземат предвид резултатите от изпитванията, извършени след поставяне на шестте допълнителни болта. Тези резултати са представени в ПРИЛОЖЕНИЕ IV, като в обобщен вид са отразени в таблицата по-долу:

ТОЧКА НОМЕР	РЕЗОНАНС (Hz)			
	Хоризонтална посока „X“ (отпред - назад)		Хоризонтална посока „Y“ (странично)	
	Начален скрининг	Краен скрининг	Начален скрининг	Краен скрининг
2 (ЦЕНТЪР НА ТЕЖЕСТТА)	11,03 (0,15 g)	10,49 (0,1 g)	7,37 (0,15 g)	7,63 (0,1 g)

В този случай при резонансите се наблюдава отклонение от порядъка на 4,9% в посока X и от порядъка на 3,5% в посока Y.

В ПРИЛОЖЕНИЕ IV са отразени трансмисионните функции (модул) на точка 2 (център на тежестта), получени с помощта на виброметър по време на локалния скрининг, при ниво на ускорения 0,15 g. Въз основа на тези функции е изчислена способността на съоръжението за поглъщане на вибрации, съответстваща на различните режими на вибриране (изчислени по метода *Ширина на лентата*), както е показано в обобщен вид по-долу:

ВЯРНО С
ОРИГИНАЛА

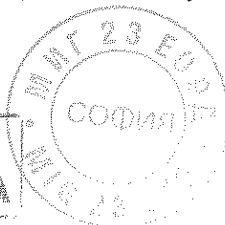

ТОЧКА НОМЕР	РЕЗОНАНС (Hz) / Способност за вибропоглъщане (%)	
	Хоризонтална посока „X“ (отпред - назад)	Хоризонтална посока „Y“ (странично)
2 (ЦЕНТЪР НА ТЕЖЕСТТА)	<u>10,15</u> / 13,45%	<u>6,12</u> / 16,11 %

Във вертикална посока не е отчетен значителен резонанс.

Кръгъл печат на ВИРЛАБ, ЛАБОРАТОРИЯ ЗА ВИБРАЦИОННИ ИЗПИТВАНИЯ

ВИРЛАБ, С.А. Подразделение на УРБАР ИНЖЕНЕРОС, С.А.	ДОКЛАД НОМЕР 111640	СТРАНИЦА НОМЕР 35/279
--	-------------------------------	---------------------------------

От друга страна, след поставяне на шестте допълнителни болта и преди извършване на синусоидалните сеизмични изпитвания са повторени локалните изпитвания, тъй като е повишена здравината на връзките между разпределителната уредба и изпитвателното оборудване. Способността на уредбата за поглъщане на вибрациите, съответстваща на отделните режими на вибриране и получена в резултат на горното изпитване, е представена в долната таблица:

ТОЧКА НОМЕР	РЕЗОНАНС (Hz) / Способност за вибропоглъщане %	
	Хоризонтална посока „X“ (отпред - назад)	Хоризонтална посока „Y“ (странично)
2 (ЦЕНТЪР НА ТЕЖЕСТТА)	<u>11,03</u> / 9,46%	<u>7,37</u> / 10,04 %

Всички тези стойности са изчислени при *Включени разединители*. Накрая е извършен локален скрининг в посока X с *Изключени разединители*, тъй като е забелязана значителна промяна в тази посока при извършване на синусоидалното сеизмично изпитване. Честотата и способността за вибропоглъщане, получени в резултат на това изпитване, са **10,54 Hz** и **6,82%**.

В **ПРИЛОЖЕНИЕ V** са показани спектрите на реагиране на изпитванията (TRS) за Група I акселерометри, закрепени върху изпитвателното оборудване, които са резултат от многочестотните сеизмични изпитвания върху *Килиите*.

Тези спектри, получени с помощта на Виброметъра, са изчислени за вибропоглъщане от **2%** при 1/24 октави; те са нанесени на графиката върху изискуемите спектри на реагиране (RRS).

ВЯРНО С
ОРИГИНАЛА

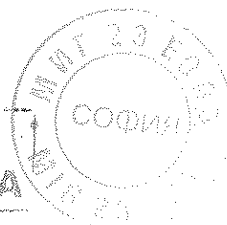

Handwritten mark

В **ПРИЛОЖЕНИЕ VI** са отразени спектрите на реагиране на изпитванията (TRS) за Група 1 акселерометри, изчислени за вибропоглъщане от 5% при 1/24 октави и получени в резултат на сеизмичните изпитвания върху *Килиите*. Тези спектри, изчислени с помощта на Виброметъра, също са нанесени на графиката върху изискуемите спектри на реагиране (RRS).

В **ПРИЛОЖЕНИЕ VII** са отразени акселограмите на Група 1 акселерометри, резултат от сеизмичните изпитвания, осъществени с многочестотно възбуждане.

Астеасу, 27 септември 2011 год.
ВИРЛАБ, С.А.
Подразделение на УРБАР ИНЖЕНИЕРОС, С.А.

Проверил:
нечетлив подпис

Алберто КОРАЛ
Лабораторен инженер

Извършил:
нечетлив подпис

Хуан Антонио ПЕРЕС
Ръководител на Лабораторията

Кръгъл печат на ВИРЛАБ, ЛАБОРАТОРИЯ ЗА ВИБРАЦИОННИ ИЗПИТВАНИЯ

Handwritten signature

Handwritten mark

ВЯРНО С
ОРИГИНАЛА

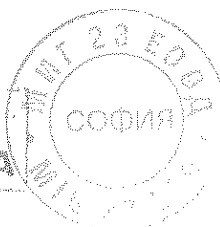

Handwritten signature

0

**INFORME DEL ENSAYO DE CUALIFICACIÓN SÍSMICA DEL
"SISTEMA CGM COSMOS L+P+V",
DE ORMAZABAL, S.A.**

NOTA: De acuerdo con lo indicado en el Apartado 5.10.2 de la Norma ISO-IEC 17025:2005, se hace constar:

- Los resultados del presente informe conciernen, única y exclusivamente a las muestras sometidas a ensayo.
- Queda prohibida la reproducción parcial de este documento sin la autorización por escrito del Laboratorio.

Fecha	Realizado por	Revisado por	VIRLAB, S.A. División de URBAR INGENIEROS, S.A.
на основание чл. 2 от ЗЗЛД			Polígono Industrial de Asteasu Zona B, Pabellón 44 20159 Asteasu (Guipúzcoa) ESPAÑA
	PEREZ	CORRAL	www.virlab.es E-mail: virlab@urbar.com Tel.: +34 943 69 15 00 Fax: +34 943 69 26 67



mm

ВЯРНО С
ОРИГИНАЛА

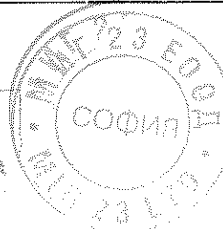

12,0.- CONCLUSIONES

Un Cuadro Eléctrico "SISTEMA CGMCOSMOS L+P+V" de ORMAZABAL, S.A., formado por tres (3) *Celdas*, según plano n° DOC-3410, Revisión 01, de fecha 08/04/11, cuyas características se describen en el punto 3,0, destinado a **SUBESTACIONES Y CENTROS DE TRANSFORMACIÓN ELECTRICOS**, ha sido sísmicamente ensayado tal y como se indica en el procedimiento descrito en el punto 8,0, conforme a la norma europea UNE EN 60068-3-3 de 1994, la norma NSR-98 (Colombia), las especificaciones ETGI-1020 (Chile), E-SE-010 (Enersis) y NSP-420 (Venezuela), apoyándose igualmente en las normas norteamericanas IEEE-344 de 2004 e IEEE-693 de 2005.

En el punto 11,0 se describen los resultados de los ensayos a los que ha sido sometido el Cuadro. Este equipo ha soportado satisfactoriamente los ensayos sin que se haya detectado anomalía ni deterioro estructural alguno en el mismo.

La única incidencia significativa habida en estos ensayos se ha presentado en el ensayo n° 21, ensayo sísmico multifrecuencial de nivel S2 realizado en dirección YZ, *tado-tado* al Cuadro y *vertical* simultáneamente, en el que se han alcanzado microdeformaciones de valor superior a 1000 (1198), valor considerado como el máximo admisible, en una (G4) de las cuatro bandas colocadas en la base del equipo.

Con objeto de reducir las tensiones en el equipo se ha aumentado el n° de tornillos desde 12 hasta 18 (**dos (2) por Celda**), reduciéndose el n° máximo de microdeformaciones desde 1198 hasta 719 en el ensayo n° 22, realizado con el mismo nivel que el ensayo n° 21.

En el **APÉNDICE I**, se encuentran dibujados los registros de las galgas extensométricas obtenidos de los ensayos sísmicos realizados, tanto de tipo multifrecuencial como de tipo senoidal, a las frecuencias de resonancia del Cuadro, no superándose, excepción hecha del caso citado, el 80% del límite de fluencia del material, definido por 1000 microdeformaciones.

En el **APÉNDICE II** se encuentran dibujados los espectros de frecuencia, integrados por valores máximos, del grupo 1 de acelerómetros, colocado sobre la plataforma vibrante, en los que se refleja el nivel aplicado en los ensayos exploratorios realizados antes y después de los ensayos sísmicos.

En este mismo **APÉNDICE** se encuentran dibujados los espectros de frecuencia del grupo 1 de acelerómetros, colocado sobre la plataforma vibrante; y del grupo 2, colocado en el Centro de Gravedad del Conjunto, en los que se refleja el nivel aplicado en los ensayos sísmicos senoidales realizados en dirección Y (*tado-tado*) y X (*frente-atrás*) al equipo.

En el **APÉNDICE III**, se encuentran las Funciones de Transferencia (*módulo y fase*) obtenidas en los ensayos exploratorios iniciales y finales, realizados con un nivel de aceleración de 0,1 g, de los que se han deducido las frecuencias de resonancia más significativas de las *Celdas*, en el rango de 0,5 a 35 Hz.



Handwritten signature

ВЯРНО С
ОРИГИНАЛА

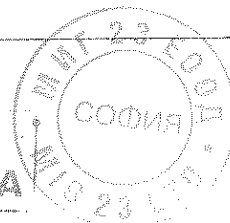

Handwritten signature

En la tabla que se acompaña a continuación se muestran las resonancias del punto 2 obtenidas en los ensayos exploratorios iniciales y finales.

PUNTO NUMERO	RESONANCIA (Hz)			
	Dirección Horizontal "X" <i>(frente-atrás)</i>		Dirección Horizontal "Y" <i>(lado-lado)</i>	
	Inicial	Final	Inicial	Final
2 (CDG)	12,87	10,49	6,68	7,63

Del análisis de estos resultados se deduce que las desviaciones entre las resonancias finales y las iniciales son del orden del 14,2% en dirección Y del orden del 18,5% en dirección X, por debajo del 20% de las admitidas por la norma IEEE693/2005.

No obstante, hay que decir a este respecto que estas desviaciones son más pequeñas si se consideran los resultados obtenidos en los ensayos realizados después de colocar los seis tornillos adicionales, resultados que se encuentran en el **APÉNDICE IV** sintetizan en la tabla siguiente:

PUNTO NUMERO	RESONANCIA (Hz)			
	Dirección Horizontal "X" <i>(frente-atrás)</i>		Dirección Horizontal "Y" <i>(lado-lado)</i>	
	Inicial	Final	Inicial	Final
2 (CDG)	11,03 <i>(0,15 g)</i>	10,49 <i>(0,1 g)</i>	7,37 <i>(0,15 g)</i>	7,63 <i>(0,1 g)</i>

Estas resonancias suponen unas desviaciones del orden del 4,9% en dirección X del orden del 3,5% en dirección Y.

En el **APÉNDICE IV**, se encuentran las funciones de transmisibilidad (*módulo*) del punto 2 (CDG) obtenidas mediante el Controlador de Vibraciones de los ensayos exploratorios locales, realizados con un nivel de aceleración de 0,15 g, a partir de las cuales se ha obtenido el amortiguamiento del equipo, asociado a sus correspondientes modos de vibración (*calculados por el Método del Ancho de Banda*), tal y como se resume a continuación:

PUNTO NUMERO	RESONANCIA (Hz) / Amortiguamiento (%)	
	Dirección Horizontal "X" <i>(frente-atrás)</i>	Dirección Horizontal "Y" <i>(lado-lado)</i>
2 (CDG)	10,15 / 13,45%	6,12 / 16,11%

En dirección vertical no se ha encontrado resonancia significativa alguna.

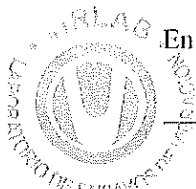

ВЯРНО С
ОРИГИНАЛА



[Handwritten signature]

Por otro lado, después de colocar los seis tornillos adicionales y antes de realizar los ensayos sísmicos de tipo senoidal, se han vuelto a repetir los ensayos exploratorios locales, debido al aumento de rigidez de la unión del Cuadro a la plataforma de ensayos, habiéndose obtenido los valores de amortiguamiento, asociados a sus correspondientes modos de vibración, que se resumen en la tabla siguiente:

PUNTO NUMERO	RESONANCIA (Hz) / Amortiguamiento (%)	
	Dirección Horizontal "X" (frente-atrás)	Dirección Horizontal "Y" (lado-lado)
2 (CDG)	11,03 / 9,46%	7,37 / 10,04%

Todos estos valores se han calculado con los *Interruptores Conectados*. Por último, se ha realizado un ensayo exploratorio local con los *Interruptores Desconectados* en dirección X, ya que se ha observado una variación significativa en esta dirección, al realizar el ensayo sísmico senoidal. La frecuencia y amortiguamiento obtenidos han sido de **10,54** Hz y 6,82%.

En el APÉNDICE V, se encuentran dibujados los Espectros de Respuesta de Ensayo (TRS), del grupo 1 de acelerómetros, colocado sobre la plataforma de ensayos, obtenidos de los ensayos sísmicos multifrecuenciales realizados sobre las *Celdas*.

Estos espectros, obtenidos con el Controlador de Vibraciones, se han calculado para el 2% amortiguamiento y por 1/24 de octava; y se encuentran superpuestos sobre los Espectros de Respuesta Requeridos (RRS).

En el APÉNDICE VI, se encuentran dibujados los Espectros de Respuesta de Ensayo (TRS), del grupo 1 de acelerómetros, calculados para el 5% amortiguamiento por 1/24 de octava, obtenidos de los ensayos sísmicos realizados sobre las *Celdas*. Estos espectros, obtenidos con el Analizador de Vibraciones, se encuentran igualmente superpuestos sobre los Espectros de Respuesta Requeridos (RRS).

En el APÉNDICE VII, se encuentran dibujados los acelerogramas del grupo 1 de acelerómetros obtenidos de los Ensayos Sísmicos realizados con excitación tipo multifrecuencial.

Asteasu, 27 de Septiembre, 2011
VIRLAB, S.A,
División de URBAR INGENIEROS, S.A,

Revisado por:

на основании чл. 2 от 33ЛД

на основании чл. 2 от 33ЛД

Alberio CORRAL
Ingeniero del Laboratorio

Juan/Antonio PEREZ
Jefe del Laboratorio



ВЯРНО С
ОРИГИНАЛА

